



Installation Guide

PTP 820S/820S Assured

System Release 10.9



**Accuracy**

While reasonable efforts have been made to assure the accuracy of this document, Cambium Networks assumes no liability resulting from any inaccuracies or omissions in this document, or from use of the information obtained herein. Cambium reserves the right to make changes to any products described herein to improve reliability, function, or design, and reserves the right to revise this document and to make changes from time to time in content hereof with no obligation to notify any person of revisions or changes. Cambium does not assume any liability arising out of the application or use of any product, software, or circuit described herein; neither does it convey license under its patent rights or the rights of others. It is possible that this publication may contain references to, or information about Cambium products (machines and programs), programming, or services that are not announced in your country. Such references or information must not be construed to mean that Cambium intends to announce such Cambium products, programming, or services in your country.

**Copyrights**

This document, Cambium products, and 3<sup>rd</sup> Party software products described in this document may include or describe copyrighted Cambium and other 3<sup>rd</sup> Party supplied computer programs stored in semiconductor memories or other media. Laws in the United States and other countries preserve for Cambium, its licensors, and other 3<sup>rd</sup> Party supplied software certain exclusive rights for copyrighted material, including the exclusive right to copy, reproduce in any form, distribute and make derivative works of the copyrighted material. Accordingly, any copyrighted material of Cambium, its licensors, or the 3<sup>rd</sup> Party software supplied material contained in the Cambium products described in this document may not be copied, reproduced, reverse engineered, distributed, merged or modified in any manner without the express written permission of Cambium. Furthermore, the purchase of Cambium products shall not be deemed to grant either directly or by implication, estoppel, or otherwise, any license under the copyrights, patents or patent applications of Cambium or other 3<sup>rd</sup> Party supplied software, except for the normal non-exclusive, royalty free license to use that arises by operation of law in the sale of a product.

**Restrictions**

Software and documentation are copyrighted materials. Making unauthorized copies is prohibited by law. No part of the software or documentation may be reproduced, transmitted, transcribed, stored in a retrieval system, or translated into any language or computer language, in any form or by any means, without prior written permission of Cambium.

**License Agreements**

The software described in this document is the property of Cambium and its licensors. It is furnished by express license agreement only and may be used only in accordance with the terms of such an agreement.

**High Risk Materials**

Cambium and its supplier(s) specifically disclaim any express or implied warranty of fitness for any high risk activities or uses of its products including, but not limited to, the operation of nuclear facilities, aircraft navigation or aircraft communication systems, air traffic control, life support, or weapons systems ("High Risk Use"). Any High Risk is unauthorized, is made at your own risk and you shall be responsible for any and all losses, damage or claims arising out of any High Risk Use.

---

# Contents

---

List of Figures.....	iv
List of Tables.....	v
<b>About This User Guide .....</b>	<b>1</b>
Contacting Cambium Networks .....	1
Purpose .....	2
Cross references.....	2
Feedback .....	2
Problems and warranty .....	3
Reporting problems.....	3
Repair and service .....	3
Hardware warranty .....	3
Security advice.....	4
Warnings, cautions, and notes .....	5
Warnings .....	5
Cautions.....	5
Notes .....	5
Caring for the environment .....	6
In EU countries .....	6
In non-EU countries.....	6
<b>Chapter 1: Product description .....</b>	<b>1-1</b>
Important Notes .....	1-2
Safety Precautions & Declared Material.....	1-3
Public and Occupational Boundary Distances Under Article 3.1(a) of the RE Directive.....	1-3
General Equipment Precautions .....	1-3
Précautions générales relatives à l'équipement .....	1-4
Allgemeine Vorsichtsmaßnahmen für die Anlage .....	1-5
<b>Chapter 2: Pre-Installation Instructions .....</b>	<b>2-1</b>
Packing.....	2-2
Transportation and Storage .....	2-2
Unpacking .....	2-2
Inspection .....	2-2
<b>Chapter 3: Product Hardware Description .....</b>	<b>3-1</b>
PTP 820S Hardware Overview .....	3-2
PTP 820S Interfaces .....	3-3
PoE Injector.....	3-4
PoE Injector Interfaces .....	3-5
System Components .....	3-6

Adaptors and Installation Kits .....	3-7
Antenna Connection .....	3-10
Power Specifications .....	3-11
Electrical Requirements .....	3-11
Important Notes .....	3-11
Environmental Specifications .....	3-12
<b>Chapter 4: Cable Installation and Grounding .....</b>	<b>4-1</b>
Minimum and Maximum Cable Diameter .....	4-2
Cable Grounding .....	4-3
To Connect the Grounding kit .....	4-3
Grounding the PTP 820S Unit .....	4-5
Power Source .....	4-6
Surge Protection .....	4-8
Securing the Cables .....	4-9
Available Cable Options .....	4-10
Fiber Optic Cables .....	4-10
DC Cable and Connector .....	4-10
Ethernet Cable and Specifications .....	4-10
Outdoor Ethernet Cable Specifications .....	4-11
Outdoor DC Cable Specifications .....	4-12
Special Instructions for use of Glands .....	4-14
General Installation Procedure .....	4-15
Connecting an Optical Fiber Cable and SFP .....	4-20
Connecting a DC Power Cable .....	4-24
Connecting the Ethernet Cable .....	4-27
Preparing the Ethernet Cable and Plug-in Field .....	4-27
Preparing the Ethernet Cable Already Assembled .....	4-30
Connection of Ethernet Cable to PTP 820S .....	4-30
Management Connection for 1+1 HSB Configurations .....	4-33
Preparing a Protection Signaling Cable .....	4-33
Connecting the Protection Splitters and Protection Signaling Cable .....	4-34
<b>Chapter 5: PoE Injector Installation and Connection .....</b>	<b>5-1</b>
PoE Injector Cable Connection .....	5-2
PoE Injector Grounding .....	5-3
PoE Injector Wall Mount Installation .....	5-4
List of Items .....	5-4
Required Tools .....	5-4
Procedure .....	5-4
PoE Injector Pole Mount Installation .....	5-6
List of Items .....	5-6
Required Tools .....	5-6
Procedure .....	5-6

PoE Injector 19" Rack Installation .....	5-8
List of Items .....	5-8
Required Tools.....	5-8
Procedure .....	5-8
PoE Injector ETSI Rack Installation.....	5-10
List of Items .....	5-10
Required Tools.....	5-10
Procedure .....	5-10
<b>Chapter 6: Generic Installation Procedures and Notes.....</b>	<b>6-1</b>
Torque Requirements .....	6-2
Pole Mount Installation .....	6-3
PTP 820S DC Pole Mount Procedure .....	6-3
<b>Chapter 7: PTP 820S Detailed Configurations Description.....</b>	<b>7-1</b>
1+0 Direct Mount Installation.....	7-2
List of Items .....	7-2
Required Tools.....	7-2
Procedure .....	7-2
2+0 Dual Polarization Direct Mount .....	7-5
List of Items .....	7-5
Required Tools.....	7-5
Procedure .....	7-5
2+0 Dual Polarization Remote Mount .....	7-8
List of Items .....	7-8
Required Tools.....	7-8
Common Installation Procedures .....	7-9
1+1HSB/2+0 Single Polarization Direct Mount .....	7-14
List of Items .....	7-14
Required Tools.....	7-14
Procedure .....	7-14
1+1HSB/2+0 Single Polarization Remote Mount .....	7-17
List of Items .....	7-17
Required Tools.....	7-17
Procedure .....	7-18
Mediation Device Losses.....	7-21
<b>Chapter 8: Acceptance and Commissioning Procedures.....</b>	<b>8-22</b>
Site Acceptance Procedure .....	8-23
Site Acceptance Checklist Notes .....	8-27
Radio Link Commissioning Procedure.....	8-29
Scope .....	8-29
Commissioning Test .....	8-29
PTP 820 Commissioning Log .....	8-31

## List of Figures

Figure 1 PTP 820S Rear View (Left) and Front View (Right).....	3-2
Figure 2 Cable Gland Construction .....	3-2
Figure 3 PTP 820S Interfaces .....	3-3
Figure 4 PoE Injector.....	3-4
Figure 5 PoE Injector Ports .....	3-5
Figure 6 System components.....	3-6
Figure 7 Grounding cable.....	4-3
Figure 8 Cable design .....	4-11
Figure 9 Glands .....	4-14
Figure 10 Removing glands.....	4-15
Figure 11 Protection Signaling Cable Pinouts .....	4-33
Figure 12 PoE Injector cable connection .....	5-2
Figure 13 PoE Injector Wall Mount Installation.....	5-4
Figure 14 PoE Injector Pole Mount Installation.....	5-7
Figure 15 Mount PTP 820S DC Pole Mount to Pole .....	6-3
Figure 16 Horizontal / Vertical Pole.....	7-3
Figure 17 Twist orientation.....	7-3
Figure 18 2+0 Dual Polarization Direct Mount .....	7-5
Figure 19 2+0 Dual Polarization Remote Mount .....	7-8
Figure 20 1+1HSB/2+0 Single Polarization Direct Mount .....	7-14
Figure 21 1+1HSB/2+0 Single Polarization Remote Mount .....	7-17

## List of Tables

Table 1 PoE Injector part number .....	3-4
Table 2 Adaptors and installation kits for 6 to 18 GHz .....	3-7
Table 3 Adaptors and installation kits for 23 to 38 GHz .....	3-7
Table 4 Remote Mount – 6 to 15 GHz .....	3-8
Table 5 Remote Mount – 18 to 38 GHz .....	3-8
Table 6 Antenna Circ. Adapters for OMT for 6 to 18 GHz.....	3-9
Table 7 Antenna Circ. Adapters for OMT for 12 to 38 GHz.....	3-9
Table 8 PoE Injector .....	3-9
Table 9 Antenna list .....	3-10
Table 10 Cable Grounding Kit. ....	4-3
Table 11 Fiber Optic cables part numbers .....	4-10
Table 12 DC cable and connector .....	4-10
Table 13 DC cable and connector .....	4-10
Table 14 Ethernet cable Color Code .....	4-11
Table 15 Ethernet Cable Electrical Requirements .....	4-11
Table 16 Outdoor DC Cable Electrical Requirements .....	4-12
Table 17 Glands kit .....	4-14
Table 18 Materials for preparing Ethernet Data Cables. ....	4-27
Table 19 Required items for Wall Mount PoE Injector .....	5-4
Table 20 Required item for 19" Rack Installation PoE Injector.....	5-8
Table 21 Required items PoE Injector ETSI Rack.....	5-10
Table 22 Required items for 1+1 Direct Mount configuration .....	6-3
Table 23 Required items for 1+1 Direct Mount configuration .....	7-2
Table 24 Required items for 2+0 Dual polarization direct mount configuration.....	7-5
Table 25 Required items for 2+0 Dual polarization direct mount configuration.....	7-8
Table 26 Required items for 1+1HSB/2+0 Single Polarization Direct Mount configuration .....	7-14
Table 27 Required items for 1+1HSB/2+0 Single Polarization Remote Mount configuration.....	7-17
Table 28 PTP 820S Mediation Device Losses .....	7-21

---

# About This User Guide

---

This guide describes the PTP 820S installation procedures and provides additional information concerning system parts and frequency bands

This guide contains the following chapters:

- [Chapter 1: Product description](#)
- [Chapter 2: Pre-Installation Instructions](#)
- [Chapter 3: Product Hardware Description](#)
- [Chapter 4: Cable Installation and Grounding](#)
- [Chapter 5: PoE Injector Installation and Connection](#)
- [Chapter 6: Generic Installation Procedures and Notes](#)
- [Chapter 7: PTP 820S Detailed Configurations Description](#)
- [Chapter 8: Acceptance and Commissioning Procedures](#)

## Contacting Cambium Networks

Support website:	<a href="https://support.cambiumnetworks.com">https://support.cambiumnetworks.com</a>
Main website:	<a href="http://www.cambiumnetworks.com">http://www.cambiumnetworks.com</a>
Sales enquiries:	<a href="mailto:solutions@cambiumnetworks.com">solutions@cambiumnetworks.com</a>
Support enquiries:	<a href="https://support.cambiumnetworks.com">https://support.cambiumnetworks.com</a>
Repair enquiries	<a href="https://support.cambiumnetworks.com">https://support.cambiumnetworks.com</a>
Telephone number list:	<a href="http://www.cambiumnetworks.com/support/contact-support">http://www.cambiumnetworks.com/support/contact-support</a>
Address:	Cambium Networks Limited, Linhay Business Park, Eastern Road, Ashburton, Devon, UK, TQ13 7UP



## Purpose

Cambium Networks Point-To-Point (PTP) documents are intended to instruct and assist personnel in the operation, installation and maintenance of the Cambium PTP equipment and ancillary devices. It is recommended that all personnel engaged in such activities be properly trained.

Cambium disclaims all liability whatsoever, implied or express, for any risk of damage, loss or reduction in system performance arising directly or indirectly out of the failure of the customer, or anyone acting on the customer's behalf, to abide by the instructions, system parameters, or recommendations made in this document.

## Cross references

References to external publications are shown in italics. Other cross references, emphasized in blue text in electronic versions, are active links to the references.

This document is divided into numbered chapters that are divided into sections. Sections are not numbered, but are individually named at the top of each page, and are listed in the table of contents.

## Feedback

We appreciate feedback from the users of our documents. This includes feedback on the structure, content, accuracy, or completeness of our documents. Send feedback to [support@cambiumnetworks.com](mailto:support@cambiumnetworks.com).

# Problems and warranty

---

## Reporting problems

If any problems are encountered when installing or operating this equipment, follow this procedure to investigate and report:

- 1 Search this document and the software release notes of supported releases.
- 2 Visit the support website.
- 3 Ask for assistance from the Cambium product supplier.
- 4 Gather information from affected units, such as any available diagnostic downloads.
- 5 Escalate the problem by emailing or telephoning support.

## Repair and service

If unit failure is suspected, obtain details of the Return Material Authorization (RMA) process from the support website.

## Hardware warranty

Cambium's standard hardware warranty is for one (1) year from date of shipment from Cambium Networks or a Cambium distributor. Cambium Networks warrants that hardware will conform to the relevant published specifications and will be free from material defects in material and workmanship under normal use and service. Cambium shall within this time, at its own option, either repair or replace the defective product within thirty (30) days of receipt of the defective product. Repaired or replaced product will be subject to the original warranty period but not less than thirty (30) days.

To register PTP products or activate warranties, visit the support website. For warranty assistance, contact the reseller or distributor.

**Caution**

Using non-Cambium parts for repair could damage the equipment or void warranty. Contact Cambium for service and repair instructions.

Portions of Cambium equipment may be damaged from exposure to electrostatic discharge. Use precautions to prevent damage.

## Security advice

---

Cambium Networks systems and equipment provide security parameters that can be configured by the operator based on their particular operating environment. Cambium recommends setting and using these parameters following industry recognized security practices. Security aspects to be considered are protecting the confidentiality, integrity, and availability of information and assets. Assets include the ability to communicate, information about the nature of the communications, and information about the parties involved.

In certain instances, Cambium makes specific recommendations regarding security practices, however the implementation of these recommendations and final responsibility for the security of the system lies with the operator of the system.

# Warnings, cautions, and notes

---

The following describes how warnings and cautions are used in this document and in all documents of the Cambium Networks document set.

## Warnings

Warnings precede instructions that contain potentially hazardous situations. Warnings are used to alert the reader to possible hazards that could cause loss of life or physical injury. A warning has the following format:

**Warning**

Warning text and consequence for not following the instructions in the warning.

## Cautions

Cautions precede instructions and are used when there is a possibility of damage to systems, software, or individual items of equipment within a system. However, this damage presents no danger to personnel. A caution has the following format:

**Caution**

Caution text and consequence for not following the instructions in the caution.

## Notes

A note means that there is a possibility of an undesirable situation or provides additional information to help the reader understand a topic or concept. A note has the following format:

**Note**

Note text.

# Caring for the environment

---

The following information describes national or regional requirements for the disposal of Cambium Networks supplied equipment and for the approved disposal of surplus packaging.

## In EU countries

The following information is provided to enable regulatory compliance with the European Union (EU) directives identified and any amendments made to these directives when using Cambium equipment in EU countries.



## Disposal of Cambium equipment

European Union (EU) Directive 2002/96/EC Waste Electrical and Electronic Equipment (WEEE)

Do not dispose of Cambium equipment in landfill sites. For disposal instructions, refer to <http://www.cambiumnetworks.com/support>

## Disposal of surplus packaging

Do not dispose of surplus packaging in landfill sites. In the EU, it is the individual recipient's responsibility to ensure that packaging materials are collected and recycled according to the requirements of EU environmental law.

## In non-EU countries

In non-EU countries, dispose of Cambium equipment and all surplus packaging in accordance with national and regional regulations.

---

# Chapter 1: Product description

---

Cambium's PTP 820S represents a new generation of radio technology, capable of high bit rates and longer reach, and suitable for diverse deployment scenarios.

PTP 820S supports cutting edge capacity-boosting techniques, such as QPSK to 2048 QAM and Header De-Duplication, to offer a high capacity solution for every network topology and every site configuration. Its green, compact, all-outdoor configuration makes PTP 820S ideal for any location.

This chapter includes:

- [Important Notes](#)
- [Safety Precautions & Declared Material](#)

## Important Notes

---

- For the warranty to be honored, install the unit in accordance with the instructions in this manual.
- Any changes or modifications of equipment not expressly approved by the manufacturer could void the user's authority to operate the equipment and the warranty for such equipment.
- PTP 820S is intended for installation in a restricted access location.
- PTP 820S must be installed and permanently connected to protective earth by qualified service personnel in accordance with applicable national electrical codes.

# Safety Precautions & Declared Material

---

## Public and Occupational Boundary Distances Under Article 3.1(a) of the RE Directive

Based on the highest nominal output power of the IP-20S:

- The public exposure of compliance boundary distance is 4.8m.
- The occupational exposure of compliance boundary distance is 1.2m. This is the worst case for the highest nominal output power, using 10-13 GHz frequency bands and antennas up to 1 ft. For all other configurations, the compliance boundary distance is 0.

Note that even when the compliance boundary is a non-zero value, this only applies within the bore sight of the antenna dish. Therefore, during work within and close to the front of the antenna, make sure the transmitters are turned off. As long as the transmitters are turned off during any work on the system, the occupational exposure limit is not of concern to workers operating in or around the parabolic dish antenna.

## General Equipment Precautions

---



### Caution

To avoid malfunctioning or personnel injuries, equipment or accessories/kits/plug-in unit installation, requires qualified and trained personnel. Changes or modifications not expressly approved by Cambium Networks can void user's authority to operate the equipment.



### Caution

Where special cables, shields, adapters and grounding kits are supplied or described in this manual, these items must be used to comply with the FCC regulations.



### Caution

Use of controls, adjustments, or performing procedures other than those specified herein, may result in hazardous radiation exposure.



### Caution

When working with a PTP 820S, note the following risk of electric shock and energy hazard: Disconnecting one power supply disconnects only one power supply module. To isolate the unit completely, disconnect all power supplies.



### Caution

Machine noise information order: 3. GPSGV, the highest sound pressure level amounts to 70 dB (A) or less, in accordance with ISO EN 7779.

---



**Antistatic**

Static electricity may cause body harm, as well as harm to electronic components inside the device. Anyone responsible for the installation or maintenance of the PTP 820S must use an ESD Wrist Strap. ESD protection measures must be observed when touching the unit. To prevent damage, before touching components inside the device, all electrostatic must be discharged from both personnel and tools.

---

**Caution**

In Norway and Sweden:

Equipment connected to the protective earthing of the building installation through the mains connection or through other equipment with a connection to protective earthing – and to a cable distribution system using coaxial cable, may in some circumstances create a fire hazard. Connection to a cable distribution system has therefore to be provided through a device providing electrical isolation below a certain frequency range (galvanic isolator, see EN 60728-11).

Utstyr som er koplet til beskyttelsesjord via nettplugg og/eller via annet jordtilkøpelt utstyr – og er tilkøpelt et kabel-TV nett, kan forårsake brannfare. For å unngå dette skal det ved tilkøpling av utstyret til kabel-TV nettet installeres en galvanisk isolator mellom utstyret og kabel-TV nettet.

Utrustning som är kopplad till skyddsjord via jordat vägguttag och/eller via annan utrustning och samtidigt är kopplad till kabel-TV nät kan i vissa fall medföra risk för brand. För att undvika detta skall vid anslutning av utrustningen till kabel-TV nät galvanisk isolator finnas mellan utrustningen och kabel-TV nätet.

---

## Précautions générales relatives à l'équipement

---

**Caution**

L'utilisation de commandes ou de réglages ou l'exécution de procédures autres que celles spécifiées dans les présentes peut engendrer une exposition dangereuse aux rayonnements.

---

**Caution**

L'usage de PTP 820S s'accompagne du risque suivant d'électrocution et de danger électrique : le débranchement d'une alimentation électrique ne déconnecte qu'un module d'alimentation électrique. Pour isoler complètement l'unité, il faut débrancher toutes les alimentations électriques.

---

**Caution**

Bruit de machine d'ordre - 3. GPSGV, le plus haut niveau de pression sonore s'élève à 70 dB (A) au maximum, dans le respect de la norme ISO EN 7779.

---

## Allgemeine Vorsichtsmaßnahmen für die Anlage

---

**Caution**

Wenn andere Steuerelemente verwendet, Einstellungen vorgenommen oder Verfahren durchgeführt werden als die hier angegebenen, kann dies gefährliche Strahlung verursachen.

---

**Caution**

Beachten Sie beim Arbeiten mit PTP 820S das folgende Stromschlag- und Gefahrenrisiko: Durch Abtrennen einer Stromquelle wird nur ein

---

**Caution**

Stromversorgungsmodul abgetrennt. Um die Einheit vollständig zu isolieren, trennen Sie alle Stromversorgungen ab.

Maschinenlärminformations-Verordnung - 3. GPSGV, der höchste Schalldruckpegel beträgt 70 dB(A) oder weniger gemäß EN ISO 7779.

---

---

## Chapter 2: Pre-Installation Instructions

---

This chapter describes the Pre-Installation instructions for PTP 820S.

This chapter includes:

- [Packing](#)
- [Transportation and Storage](#)
- [Unpacking](#)
- [Inspection](#)

## Packing

The equipment must be packed and sealed in moisture absorbing bags.

## Transportation and Storage

The equipment cases are prepared for shipment by air, truck, railway and sea, suitable for handling by forklift trucks and slings. The cargo must be kept dry during transportation, in accordance with ETS 300 019-1-2, Class 2.3. For sea-transport, deck-side shipment is not permitted. Carrier-owned cargo containers must be used.

It is recommended that the equipment be transported to the installation site in its original packing case.

If intermediate storage is required, the packed equipment must be stored in a dry and cool environment, and out of direct sunlight, in accordance with ETS 300 019-1-1, Class 1.2.

## Unpacking

The equipment is packed in sealed plastic bags and moisture absorbing bags are inserted. Any separate sensitive product such as printed boards, are packed in anti-static handling bags. The equipment is further packed in special designed cases.

Marking is done according to standard practice unless otherwise specified by customers. The following details must be marked:

- Customer's address
- Contract No
- Site name (if known)
- Case Number

## Inspection

Check the packing lists and ensure that correct parts numbers quantities of goods have arrived. Inspect for any damage on the cases and equipment. To report any damage or discrepancy to a Cambium Networks representative, use e-mail or fax.

---

## Chapter 3: Product Hardware Description

---

This chapter describes the PTP 820S components, interfaces and mediation devices.

This chapter includes:

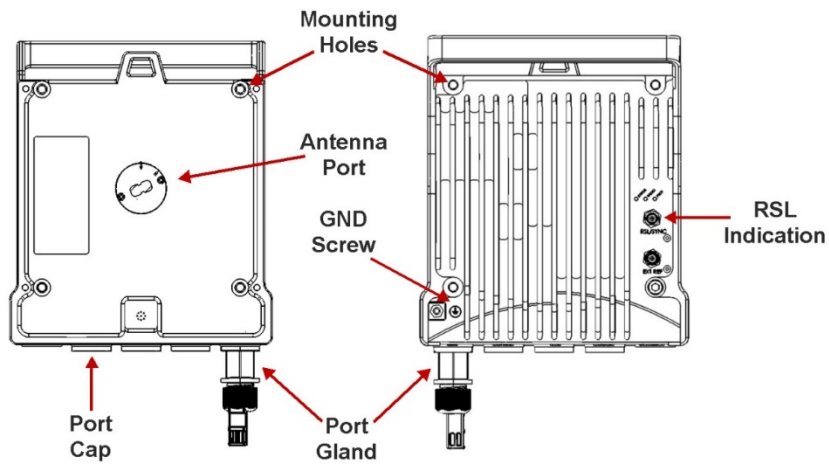
- [PTP 820S Hardware Overview](#)
- [PoE Injector](#)
- [System Components](#)
- [Adaptors and Installation Kits](#)
- [Antenna Connection](#)
- [Power Specifications](#)
- [Environmental Specifications](#)

# PTP 820S Hardware Overview

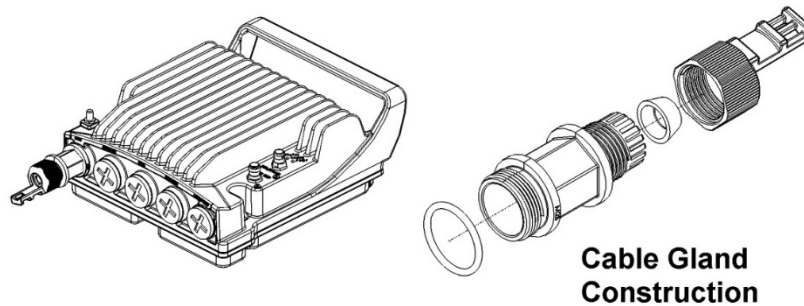
---

PTP 820S features an all-outdoor architecture consisting of a single unit directly mounted on the antenna.

**Figure 1** PTP 820S Rear View (Left) and Front View (Right)

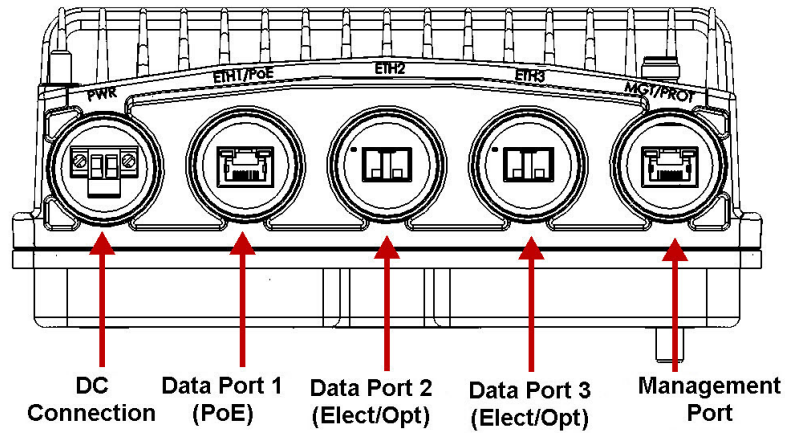


**Figure 2** Cable Gland Construction



## PTP 820S Interfaces

**Figure 3** PTP 820S Interfaces



- Data Port 1 for GbE traffic:
  - Electric: 10/100/1000Base-T. Supports PoE.
  - Optical: 1000Base-X (optional)
- Data Port 2 for GbE traffic:
  - Electric 10/100/1000Base-T
  - Optical: 1000Base-X (optional)
- Data Port 3 for GbE traffic
  - Electric: 10/100/1000Base-T
  - Optical: 1000Base-X (optional)
- Power interface (-48VDC)
- Management Port: 10/100Base-T
- 1 RF Interface – Standard interface per frequency band
- RSL interface: BNC connector
- Grounding screw

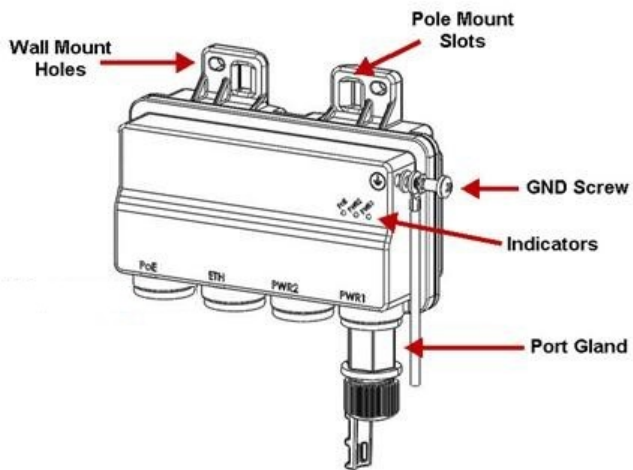
# PoE Injector

The PoE injector is an outdoor unit which can be mounted on a wall, pole or indoor rack.

Each PoE Injector kit includes the following items:

- PoE injector
- 2 caps

**Figure 4** PoE Injector



The following table lists the Cambium-approved PoE Injector:

**Table 1** PoE Injector part number

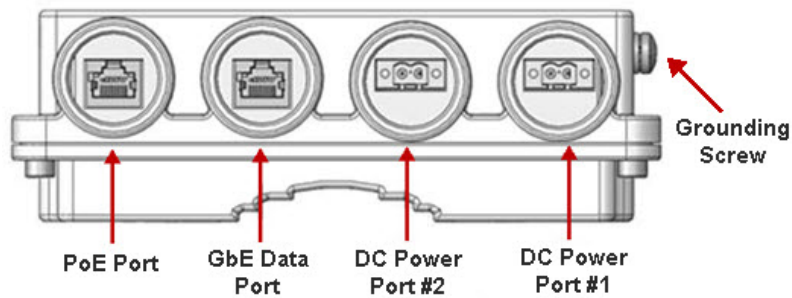
Part Number	Description
N000082L022A	Includes two DC power ports with power input ranges of $\pm(18-60)V$ each



## PoE Injector Interfaces

- Power-Over-Ethernet (PoE) Port
- GbE Data Port supporting 10/100/1000Base-T
- DC Power Port 1  $\pm(18-60)V$  or  $\pm(40-60)V$
- DC Power Port 2  $\pm(18-60)V$
- Grounding screw

**Figure 5** PoE Injector Ports



# System Components

The following figures show the main components used in the PTP 820S installation procedures.

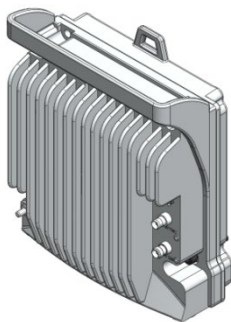


**Note**

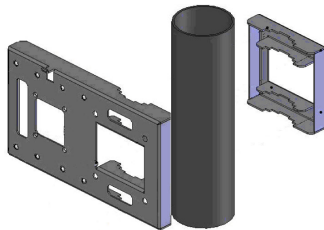
In general, the PTP 820S utilizes the exact same mediation devices as the RFU-C, unless stated otherwise.

**Figure 6** System components

PTP 820S



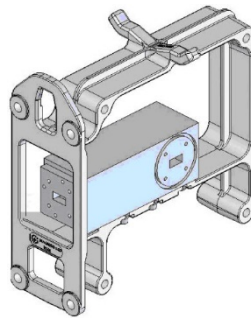
Remote Pole Mount



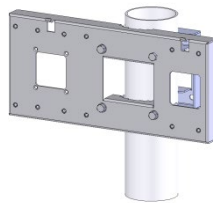
Remote Mount for 4+0



Coupler



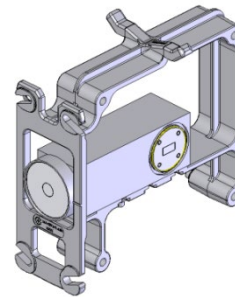
Remote Dual Pole Remote Mount



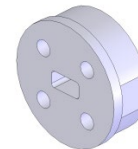
Twist



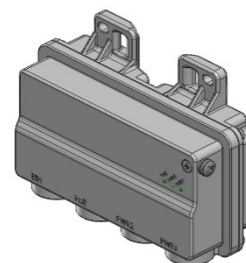
OMT



4+0/4+4 Extender



PoE Injector



## Adaptors and Installation Kits

**Table 2** Adaptors and installation kits for 6 to 18 GHz

Description	6GHz	7-8GHz	10-11GHz	13GHz	15GHz	18GHz
RFU-C Coupler KIT	N060082L145A	N070082L301A	N110082L090A	N130082L058A	N150082L080A	N180082L046A
RFU-C Symmetrical Coupler KIT	N060082L149A	N070082L305A	N110082L094A	N130082L062A	N150082L084A	N180082L050A
RFU-C Twist KIT	N060082L148A	N070082L304A	N110082L093A	N130082L061A	N150082L083A	N180082L049A
RFU-C OMT KIT	N060082L146A	N070082L302A	N110082L091A	N130082L059A	N150082L081A	N180082L047A

**Table 3** Adaptors and installation kits for 23 to 38 GHz

Description	23GHz	26GHz	28-31GHz	32GHz	38GHz
RFU-C Coupler KIT	N230082L037A	N260082L030A	N280082L040A	N320082L023A	N380082L047A
RFU-C Symmetrical Coupler KIT	N230082L040A	N260082L033A	N280082L043A	N320082L026A	N380082L051A
RFU-C Twist KIT	N230082L036A		N280082L039A		N380082L050A
RFU-C OMT KIT	N230082L038A	N260082L031A	N280082L041A	N320082L024A	N380082L048A

**Table 4** Remote Mount – 6 to 15 GHz

Remote Mount	6 GHz	7 GHz - 8GHz	10 GHz - 11GHz	13 GHz	15 GHz
RFU-C Remote Mount KIT	N000082L121A	N000082L121A	N000082L121A	N000082L121A	N000082L121A
PTP 820C DC Remote Mount KIT	N000082L120A	N000082L120A	N000082L120A	N000082L120A	N000082L120A
RFU-C Adaptor Remote Mount KIT	N060082L003A	N070082L001A	N110082L001A	N130082L001A	
RFU-C WG Kit	N060082L156A	N070082L004A	N110082L105A	N130082L070A	N150082L092A

**Table 5** Remote Mount – 18 to 38 GHz

Remote Mount	18 GHz	23 GHz	26 GHz	28 GHz	32 GHz	38 GHz
RFU-C Remote Mount KIT	N000082L121A	N000082L121A	N000082L121A	N000082L121A	N000082L121A	N000082L121A
PTP 820C DC Remote Mount KIT	N000082L120A	N000082L120A	N000082L120A	N000082L120A	N000082L120A	N000082L120A
RFU-C Adaptor Remote Mount KIT						
RFU-C WG Kit	N180082L058A	N180082L058A	N180082L058A	N280082L048A	N280082L048A	N280082L048A

**Table 6** Antenna Circ. Adapters for OMT for 6 to 18 GHz

Antenna Circ. Adapters for OMT	6GHz	7-8GHz	10-11GHz	13GHz	15GHz	18GHz
CommScope	N060082L147A	N070082L303A	N110082L092A	N130082L060A	N150082L082A	N180082L048A
Radio Waves	N060082L154A	N070082L310A	N110082L103A	N130082L068A	N150082L090A	N180082L056A
CNT	N060082L155A	N070082L311A	N110082L104A	N130082L069A	N150082L091A	N180082L057A

**Table 7** Antenna Circ. Adapters for OMT for 12 to 38 GHz

Antenna Circ. Adapters for OMT	23GHz	26GHz	28GHz	32GHz	38GHz
CommScope	N230082L039A	N260082L032A	N280082L042A	N320082L025A	N380082L049A
Radio Waves	N230082L046A	N260082L038A	N280082L046A	NA	N380082L054A
CNT	N230082L047A	N260082L039A	N280082L047A	N320082L030A	N380082L055A

**Table 8** PoE Injector

Cambium Part Number	Description
N000082L022A	PoE Injector all outdoor, redundant DC input, +24VDC support and -48VDC support
N000082L020A	PoE Injector 19" Rack Mount Kit
N000082L021A	PoE Injector ETSI Rack Mount Kit

# Antenna Connection

PTP 820S can be mounted directly for all frequencies (6-38 GHz) using the following antenna types (for integrated antennas, specific antennas part numbers are required):

- CommScope: VHLP series
- Radiowaves: HP series
- Cambium: CNT series

For remote mount installations, the following Flexible Waveguide flanges should be used (millimetric). The same antenna type (integrated) as indicated above can be used (recommended).

Other antenna types using the flanges listed in the table below may also be used.

**Table 9** Antenna list

Frequency		Circ. WG Diameter	Rect. WG Flange Des.	Radio Side (Remote) Flange Des.	Flex WG Side A Flange Des.	Flex WG Side B Flange Des.	Antenna (Remote) Flange Des.
Band	Range (GHz)						
6(L/U) GHz	5.8-7.1	31.8 mm	WR137	UDR70	PDR70	PDR70	UDR70
7/8 GHz	7.1-8.5	26 mm	WR112	UBR84	PBR84	PBR84	UBR84
10/11 GHz	10.0-11.7	18 mm	WR90	UBR100	PBR100	PBR100	UBR100
13 GHz	12.7-13.3	15 mm	WR75	UBR120	PBR120	PBR120	UBR120
15 GHz	14.5-15.4	13.5 mm	WR62	UBR140	PBR140	PBR140	UBR140
18 GHz	17.7-19.7	10.5 mm	WR42	UBR220	PBR220	PBR220	UBR220
23 GHz	21.2-23.6	9 mm					
26 GHz	24.5-26.6	8 mm					
28-31 GHz	27.3-29.5	7 mm	WR28	UBR320	PBR320	PBR320	UBR320
32 GHz	31.8-33.4	6.5 mm					
38 GHz	37.0-40.0	5.5 mm					

If a different antenna type (CPR flange) is used, a flange adaptor is required. Please contact your Cambium Networks representative for details.



**Note**

Appropriate lubricant or grease can be applied to the screws that connect the PTP 820S to the antenna interface.

# Power Specifications

---

## Electrical Requirements

- -48V DC Nominal
- Maximum current rating 1.5 A
- Maximum Cable length 300 meter
- Maximum cable size for PoE cable is 24 AWG, with maximum current up to 2A from the power source.

## Important Notes

- The unit must only be installed by service personnel.
- The unit must have a permanent connection to protective grounding.
- Data port 2, Data port 3, the Management port and the TNC connector do not provide protection from over-voltages on telecommunication networks for host equipment users.
- The RSL interface connector is intended for technician use only.
- Disconnect device (circuit breaker) in the building installation: Shall be readily accessible and incorporated external to the equipment.
- The maximum rating of the overcurrent protection can be up to 6 Amp.

# Environmental Specifications

---

Operating: ETSI EN 300 019-1-4 Class 4.1

Temperature range for continuous operating temperature with high reliability:

-33°C (-27°F) to +55°C (131°F)

Temperature range for exceptional temperatures; tested successfully, with limited margins:

-45°C (-49°F) to +60°C (140°F)

Humidity: 5%RH to 100%RH

IEC529 IP66

Storage: ETSI EN 300 019-1-1 Class 1.2

Transportation: ETSI EN 300 019-1-2 Class 2.3



---

# Chapter 4: Cable Installation and Grounding

---

This chapter describes the PTP 820S cable installation and grounding procedure.

This chapter includes:

- [Minimum and Maximum Cable Diameter](#)
- [Cable Grounding](#)
- [Surge Protection](#)
- [Securing the Cables](#)
- [Available Cable Options](#)
- [Special Instructions for use of Glands](#)
- [Connecting an Optical Fiber Cable and SFP](#)
- [Connecting an Optical Fiber Cable and SFP](#)
- [Connecting a DC Power Cable](#)
- [Connecting the Ethernet Cable](#)

## Minimum and Maximum Cable Diameter

---

To fit the gland, the outer cable diameter should be between 6-10 mm. This applies to all glands on both the PTP 820S unit and the PoE Injector.

To fit the grounding clamp, the outer diameter of CAT5E Ethernet Cables must be between 6-7.1mm.

# Cable Grounding

Cables must be grounded as follows:

- For fiber cables (see [Connecting an Optical Fiber Cable and SFP](#) on page 4-20), no grounding is required.
- For DC power cables (see [connecting a DC power cable](#) on page 4-24), no grounding is required.
- For Ethernet cables, the shielded Ethernet cable (SF/UTP construction) must be grounded to the antenna tower at the top (next to the PTP 820 unit) and the indoor cabinet and every 50m using the Ethernet Cable Grounding Kit N000082L017A.

**Figure 7** Grounding cable



## To Connect the Grounding kit

**Table 10** Cable Grounding Kit.

Marketing P/N	Description
CAT5E gnd Kit	High Speed GND Kit for CAT5E SF/UTP 5.9-7.1mm outdoor cable.

## Procedure

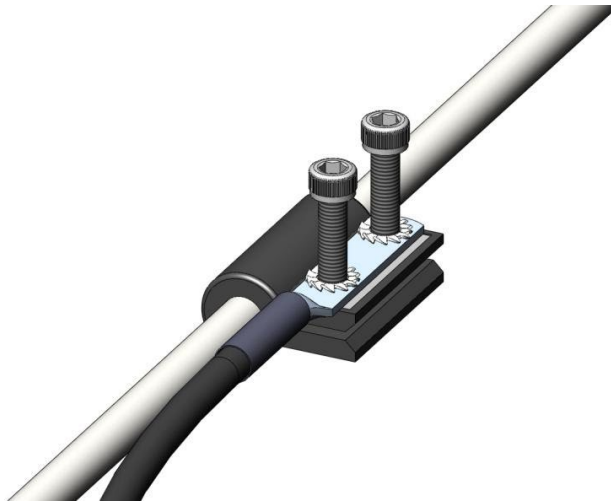
- 1 Strip the Cable jacket.



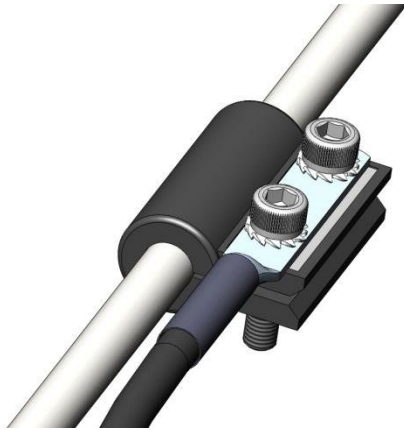
- 2 Place the cable in the middle of the grounding bracket.



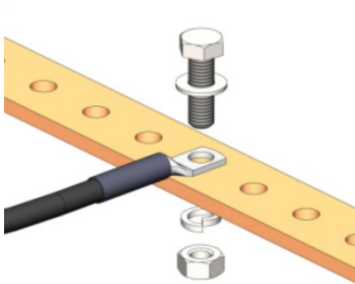
- 3 Close the grounding bracket around the cable.



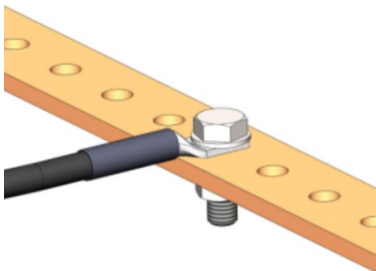
- 4 Tighten the two screws to secure the grounding bracket around the cable.



5 Install the grounding lug on the grounding bar, or directly to the tower.



6 Tighten the grounding lug



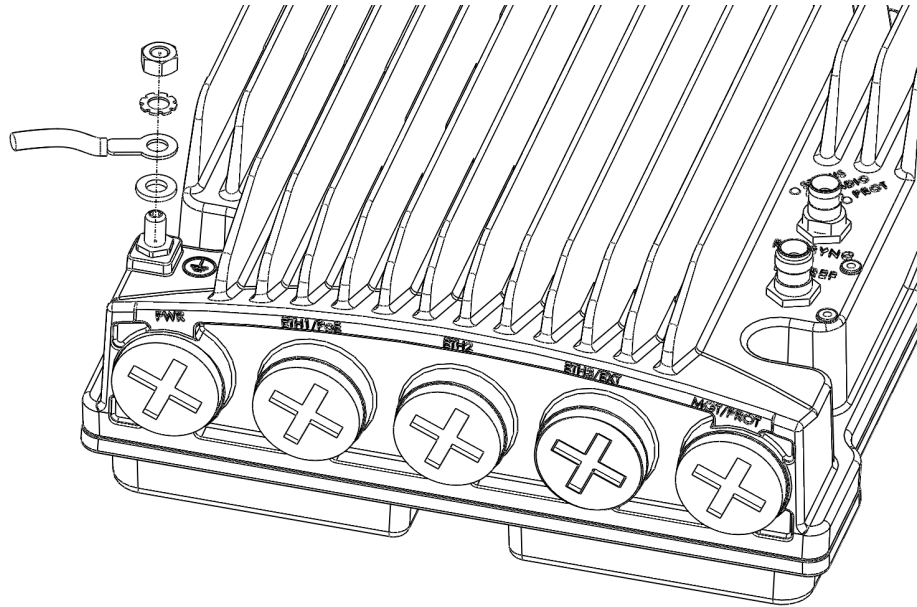
## Grounding the PTP 820S Unit

### Required Tools

- Metric offset wrench key wrench #3
- Metric wrench 10mm

### Procedure

- 1 On the front of each PTP 820S unit, loosen the nut, plain washer and serrated washer from the GND stud, using the metric offset hexagon key and the wrench.



- 2 Place the cable lug (supplied with the grounding kit) on the screw.
- 3 Secure the cable lug.
- 4 The second side of the GND cable should be connected to the main ground bar or terminal ground bar of the site.
- 5 Perform a resistance test between the 2 lugs of the GND cable. Verify that the result is 0-2 ohms.



#### Note

The unit's grounding screw terminal is permanently connected to protective earth in a building installation in accordance with applicable national code and regulations by a service person.

A 2-pole circuit breaker, a branch circuit protector, suitably certified in accordance with applicable national code and regulations, rated maximum 20A, shall be installed for full power disconnection in a building installation.

Any outdoor antenna cable shield is permanently connected to protective earth in a building installation.

## Power Source

The Power cable must be plugged into the unit before turning on the external power.

When selecting a power source, the following must be considered:

DC power can be from -40 VDC to -60 VDC.



**Warning**

Availability of a UPS (Uninterrupted Power Source), battery backup and emergency power generator is desirable.

The power supply must have grounding points on the AC and DC sides.



**Caution**

The user power supply GND must be connected to the positive pole in the PTP 820S power supply. Any other connection may cause damage to the system.



**Note**

For the warranty to be honored, you must install the PTP 820S in accordance with the instructions above.

# Surge Protection

---

PTP 820S includes built-in surge protection for its Ethernet and power interfaces. PTP 820S's surge protection implementation complies with surge immunity standard IEC 61000-4-5, level 4, provided the Ethernet cables were prepared according to the instructions in [Preparing the Ethernet Cable and Plug-in Field](#) on page 4-27.

In areas in which severe lightning conditions are likely to occur, it is strongly recommended to add additional protection by placing lightning protectors on all electrical Ethernet cables, near the connection points with the PTP 820S unit.



## Securing the Cables

---

All cables must be secured at every meter on-site using a suitable Outdoor Cable Tie. Take special care to apply the proper amount of force in order to avoid damage to the cable. This is especially important for optical (SFP) cables.

# Available Cable Options

---

## Fiber Optic Cables

**Table 11** Fiber Optic cables part numbers

Marketing P/N	Description
N000082L139A	PTP 820 Optical cable, SM, 30m
N000082L140A	PTP 820 Optical cable, SM, 50m
N000082L141A	PTP 820 Optical cable, SM, 80m
N000082L142A	PTP 820 Optical cable, SM, 100m
N000082L143A	PTP 820 Optical cable, SM, 150m
N000082L146A	PTP 820 Fiber 1+1 Splitter, SM
N000082L147A	PTP 820 Fiber Adapter

## DC Cable and Connector

**Table 12** DC cable and connector

Part Number	Description
N000082L019A	PTP 820 Outdoor_DC_cbl_2x18AWG_drum
N000082L065A	PTP 820 DC Connector

## Ethernet Cable and Specifications

**Table 13** DC cable and connector

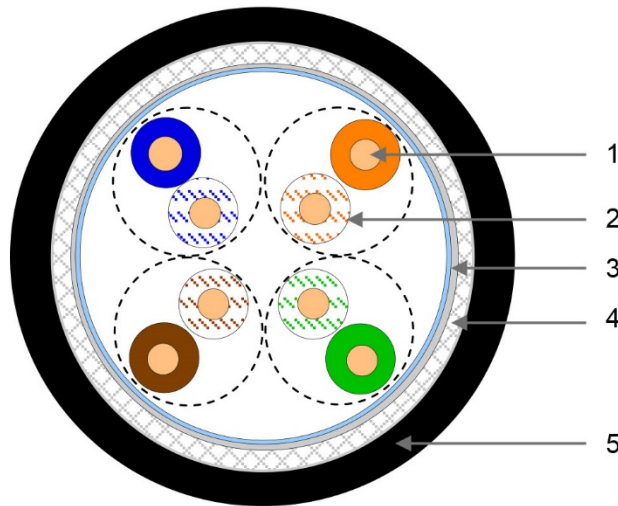
Part Number	Description
N000082L015A	CAT5E_Outdoor_305m_drum

This cable is suitable for:

- Fast Ethernet
- Gigabit Ethernet
- PoE

The following figure shows the cable design. The numbers in the figure refer to the items listed beneath the figure.

**Figure 8** Cable design



- [1]Conductor
- [2]Insulation
- [3]Screen: Alu/Pet foil. Alu outside
- [4]Tinned copper braid
- [5]Jacket

**Table 14** Ethernet cable Color Code

Pair	Wire A	Wire B
1	WHITE-blue	BLUE
2	WHITE-orange	ORANGE
3	WHITE-green	GREEN
4	WHITE-brown	BROWN

## Outdoor Ethernet Cable Specifications

**Table 15** Ethernet Cable Electrical Requirements

Electrical Requirements	
Cable type	<b>CAT-5e SFUTP</b> , 4 pairs, according to ANSI/TIA/EIA-568-B-2
Wire gauge	24 AWG
Stranding	Solid

Voltage rating	70V	
Shielding	Braid + Foil	
Pinout	RJ45,P1	RJ45,P2
	1 ———	1 ———
	2 ———	2 ———
	3 ———	3 ———
	6 ———	6 ———
	4 ———	4 ———
	5 ———	5 ———
	7 ———	7 ———
	8 ———	8 ———
	SHELL ———	SHELL ———
	DRAIN WIRE + SHIELD	

Ethernet Cable Mechanical/ Environmental Requirements	
Jacket	UV resistant
Outer diameter	7.1mm (in order to be compatible with the grounding clamp, CAT5E gnd kit)
Operating and Storage temperature range	-40°C - 85°C
Flammability rating	According to UL-1581 VW1, IEC 60332-1
RoHS	According to Directive/2002/95/EC

## Outdoor DC Cable Specifications

**Table 16** Outdoor DC Cable Electrical Requirements

Electrical Requirements	
Cable type	2 tinned copper wires
Wire gauge	18 AWG (for <100m installations) 12 AWG (for >100m installations)
Stranding	stranded
Voltage rating	600V
Spark test	4KV
Dielectric strength	2KV AC min
Mechanical/ Environmental Requirements	

Jacket	PVC, double, UV resistant
Outer diameter	7-10 mm
Operating & Storage temperature range	-40°C - 85°C
Flammability rating	According to UL-1581 VW1, IEC 60332-1
RoHS	According to Directive/2002/95/EC

# Special Instructions for use of Glands



**Note**

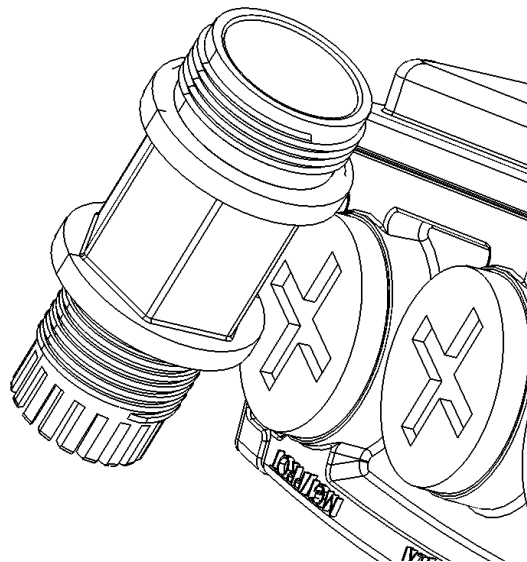
Each PTP 820S unit is supplied with two glands. If additional glands are required, they must be ordered separately, in kits of five glands each.

**Table 17** Glands kit

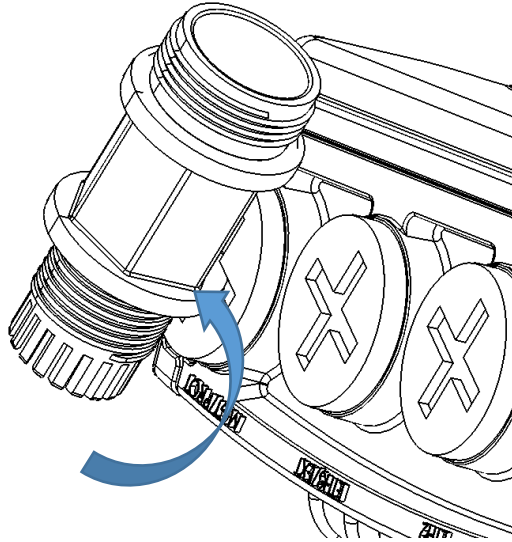
Part Number	Description
N000082L014A	PTP 820 Glands_x5_KIT

In order to remove the plastic plugs for the unit, you can use the flange of supplied glands to disconnect them. See the figures below:

**Figure 9** Glands



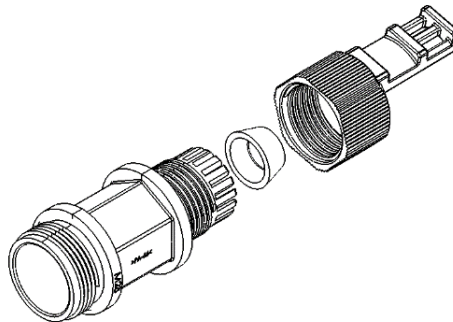
**Figure 10** Removing glands



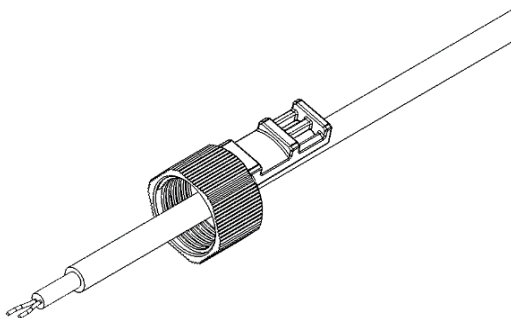
## General Installation Procedure

This procedure applies to all cable types, and explains how to install the cables using long glands. The gland is supplied assembled.

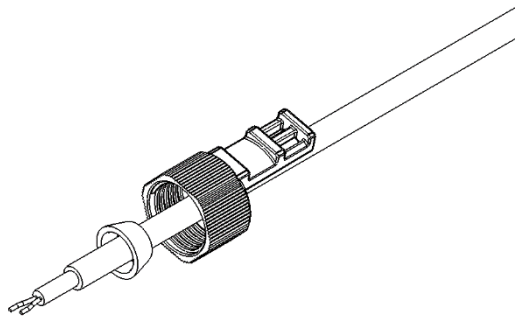
- 1 Before inserting a cable, you must disassemble the gland cap and gland rubber from the gland body



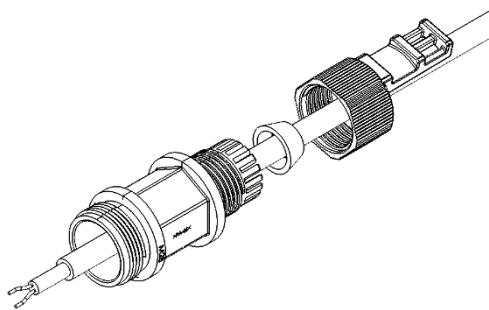
- 2 Slide the gland cap into the cable.



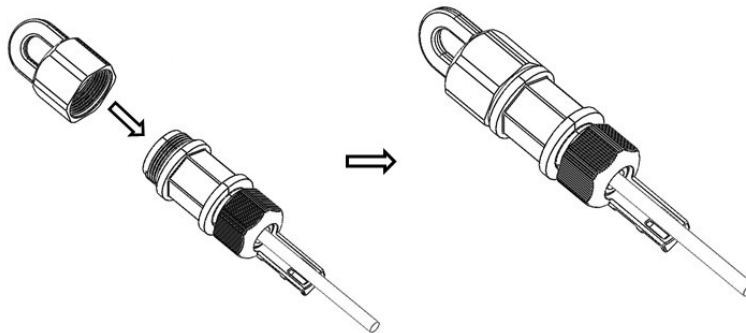
- 3 Slide the gland rubber into the cable.



- 4 Slide the cable into the body of the gland. If a gland cap is being used (see Step 5), make sure to leave enough space for the gland cap to fit into the gland without disturbing the cable.

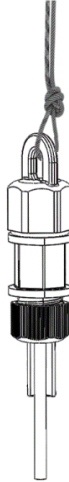


- 5 Optionally, after securing the cable into the body of the gland, close the other side of the gland with an M28 gland cap. The gland cap protects the cable and connector from damage when elevating the cable and gland to the radio unit.

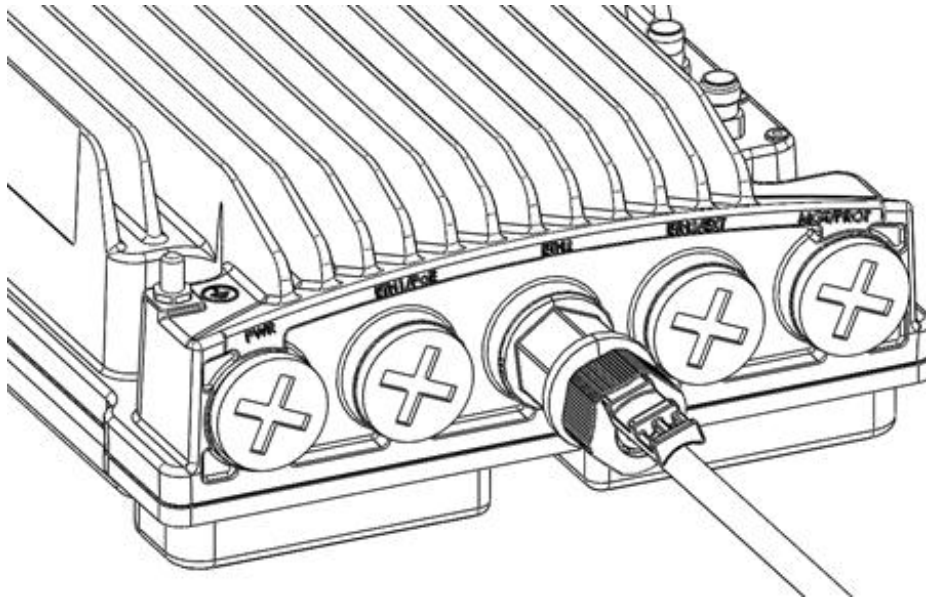


- 6 The M28 gland cap has hook on top. After attaching the gland cap to the gland, connect a rope to the hook and use this to lift the gland and cable up to the radio unit. Before securing the gland into the radio unit, remove the gland cap.





- 7 If an M28 gland cap is used to close the gland when raising the gland and cable to the radio unit, remove the gland cap from the gland at this point by unscrewing the cap.
- 8 Connect the cable to the port.
- 9 Screw the gland into the radio unit until there is full contact between the gland and the radio unit.

**Note**

Before tightening the gland, make sure the gland is aligned with the taped hole in the unit. Tightening the gland at an angle can ruin the thread on the gland and prevent proper sealing of the interface.

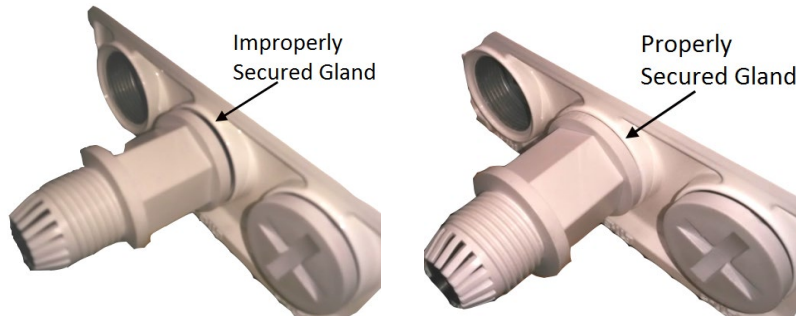
Tighten the gland gently and make sure there is no resistance. If there is resistance, stop immediately, and thread out the gland. Verify that the gland thread is not damaged and tighten the gland again.

- 10 Insert the main part of the gland into the thread in the radio body and tighten until there is full contact and the gasket is fully contained between the gland and the radio and cannot be seen. Tighten the gland gently and make sure there is no resistance. If there is resistance, stop immediately, and thread out the gland. Verify that the gland thread is not damaged and tighten the gland again.



**Caution**

Pay attention that the gland rubber is properly located and not damaged during the tightening of the gland cap. If the gland thread is damaged, do not use it!

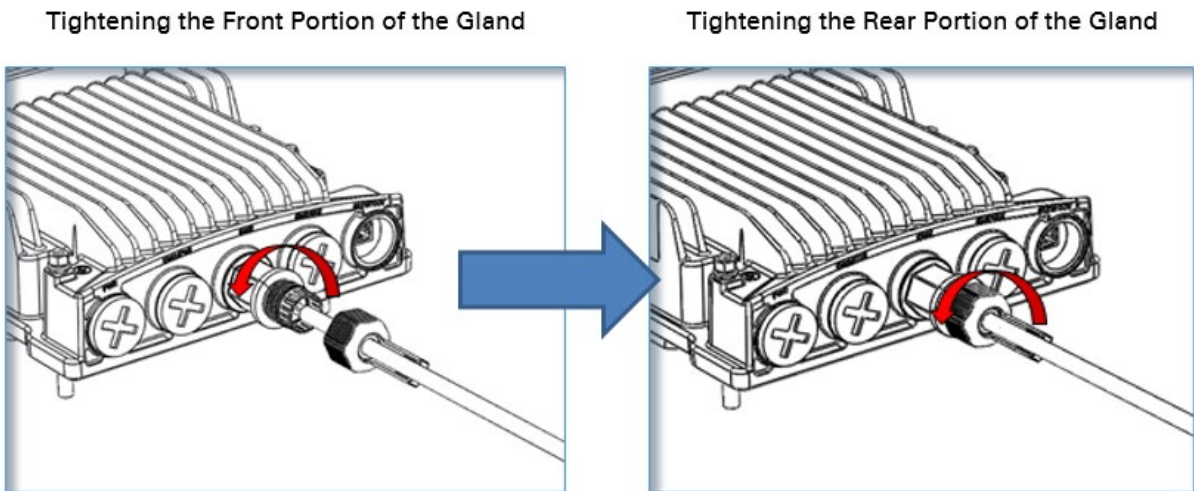


- 11 Tighten the rear portion of the gland onto the main part of the gland and make sure that the main part of the gland does not have an additional swivel after the rear portion is secured.

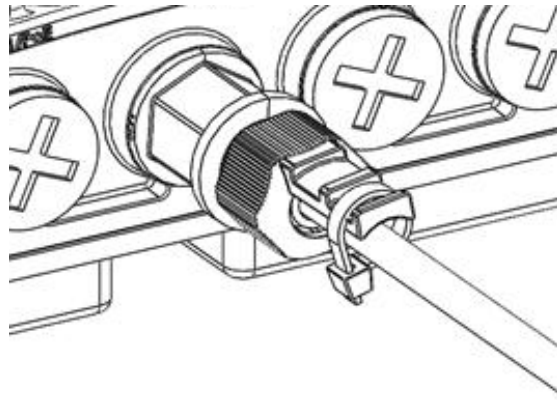


**Note**

If the main portion of the gland is rotated while the rear portion is seizing the cable, this may ruin the cable connector.



- 12 Secure the cable to the lip of the gland using a tie wrap.

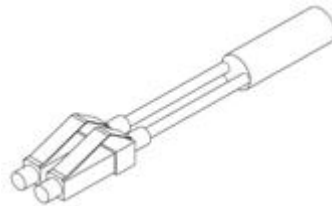


## Connecting an Optical Fiber Cable and SFP

---

To connect an optical fiber cable and the SFP transceiver:

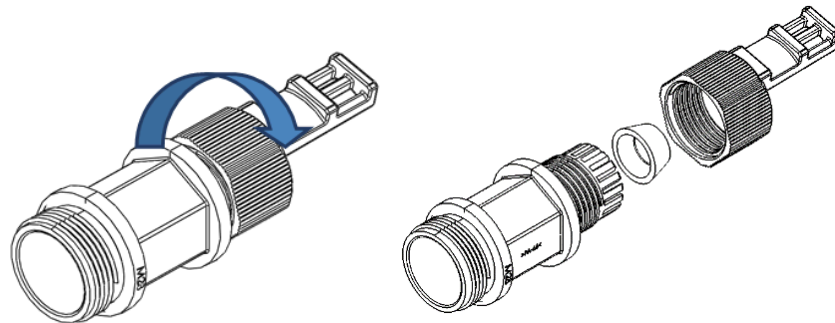
- 1 Use a pre-assembled cable.



- 2 Split the connector into two separate LC Connectors (one for each fiber).



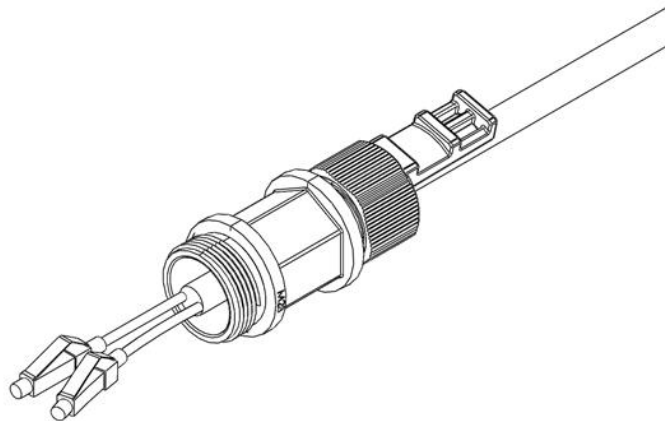
- 3 Remove the gland cap and rubber from the gland body.



- 4 Slide the gland cap into the cable.

- 5 Slide the rubber into the cable.

- 6 Insert the wires with the connectors one by one into the cable gland.



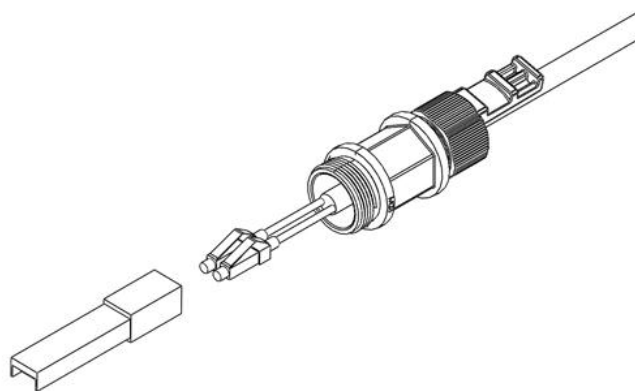
- 7 Secure the cable to the lip of the gland using a tie wrap.



**Note**

If you are raising the cable to a radio unit on a tower, this step is crucial to prevent the cable from slipping from the gland, which could damage the connector.

- 8 Connect the fibers to the SFP transceiver. Listen for the “click” to ensure that it is fully inserted.



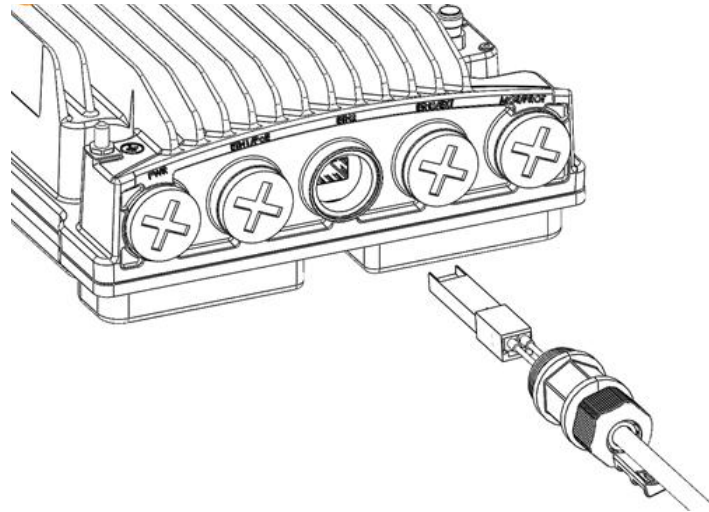
- 9 Remove the tie wrap securing the cable to the gland.



**Note**

A new tie wrap must be used to secure the cable to the gland at the end of the procedure, as described in Step 13.

- 10 Connect the connector into the PTP 820S LC connector.



- 11 Tighten the gland to the radio unit until there is full contact between the gland and the radio unit.
- 12 Tighten the gland cap.

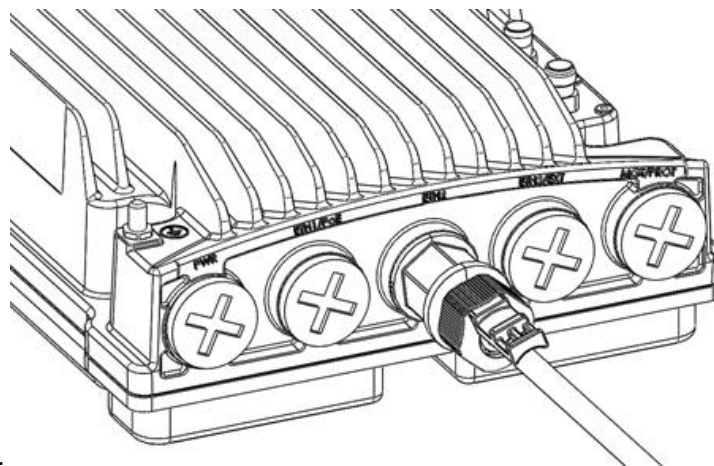
**Note**

Before tightening the gland, ensure it is aligned with the taped hole in the unit.

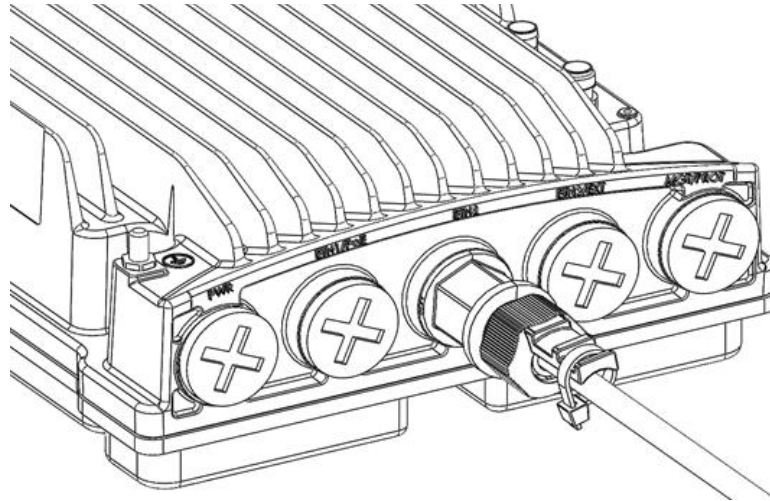
Tightening the gland at an angle can ruin the thread on the gland and prevent proper sealing of the interface. Tighten the gland gently and make sure there is no resistance. If there is resistance, stop immediately, thread out the gland, and verify that the gland threads are not damaged. Then, tighten the gland again.

**Caution**

If the gland thread is damaged do not use it.



- 13 Secure the cable to the gland using a tie wrap.

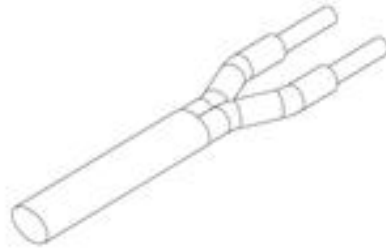


# Connecting a DC Power Cable

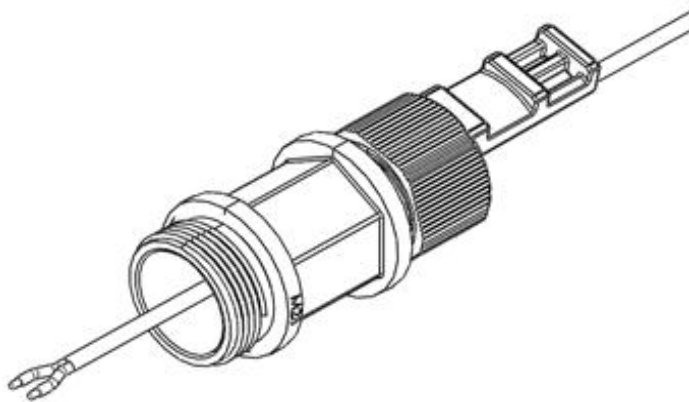
---

To connect a DC power cable:

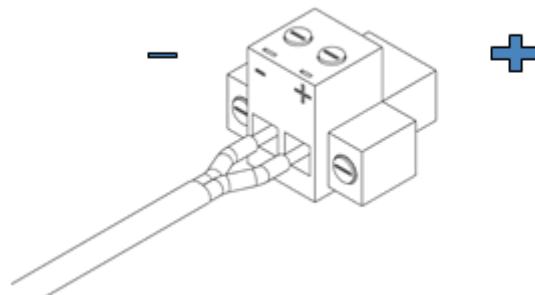
- 1 Strip off 45 mm from the cable jacket.
- 2 Expose 10 mm at the edge of each of the two wires.



- 3 Insert the power cable into the gland.

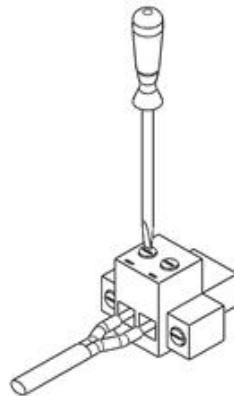


- 4 Insert the power cable wires into the power connector.
- 5 Insert the power cable wires into the power connector. Match “+” to the 0V wire and “-” to the -48V wire.

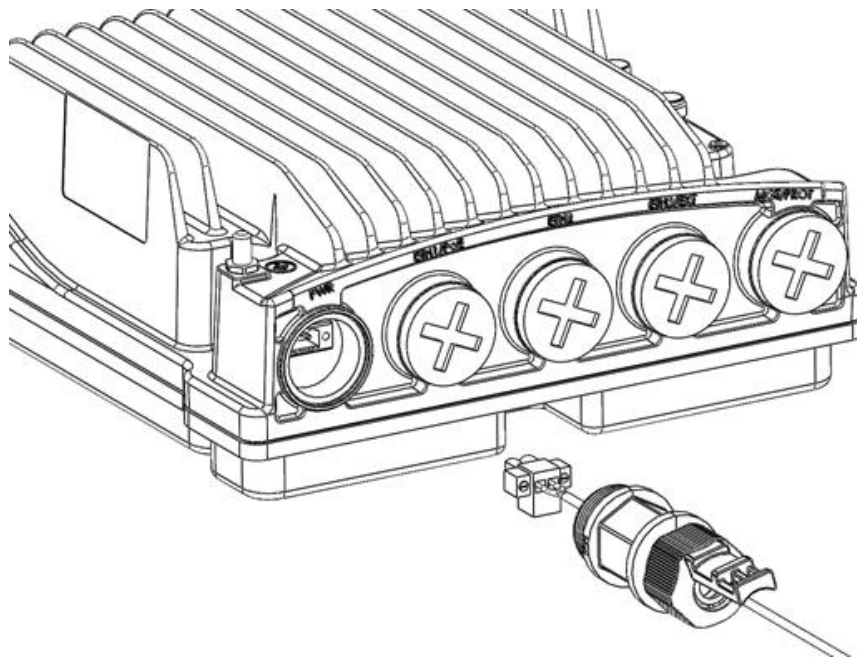




- 6 Tighten the two top screws.



- 7 Plug the power cable with connector into the PTP 820S power connector.

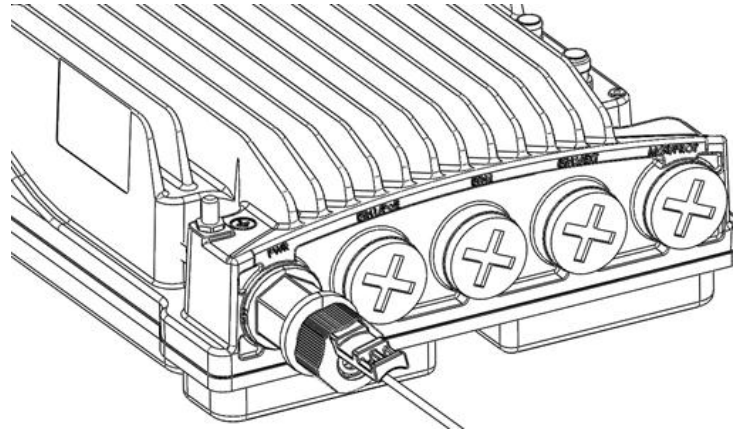


- 8 Tighten the two front screws.  
9 Screw the gland into the radio unit

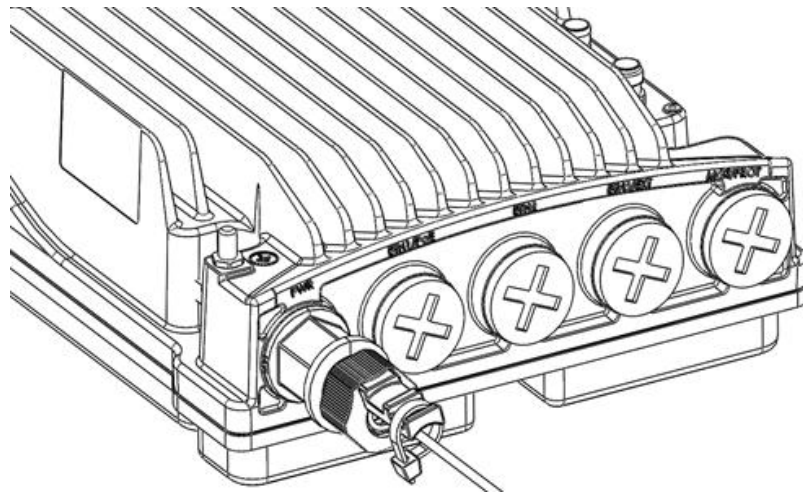


**Caution**

Before tightening the gland, make sure the gland is even with the cover. Tighten the gland gently and make sure there is no resistance. If there is resistance, stop immediately and verify that the gland is not being inserted at an angle. Tightening the gland at an angle can ruin the thread on the gland and prevent proper sealing of the interface.



- 10 Tighten the gland cap.
- 11 Secure the cable to the gland with a tie wrap.



## Connecting the Ethernet Cable

If you need to assemble the Ethernet cable, follow the instructions in section [Preparing the Ethernet Cable and Plug-in Field](#), then proceed to section [Connection of Ethernet Cable to PTP 820S](#).

If you using a pre-assembled Ethernet cable, follow the instructions in section [Preparing the Ethernet Cable Already Assembled](#), then proceed to section [Connection of Ethernet Cable to PTP 820S](#).



### Note

To ensure proper grounding and connectivity, it is recommended to use pre-assembled Ethernet cables.

## Preparing the Ethernet Cable and Plug-in Field



### Note

To ensure proper grounding, the RJ-45 plug must be shielded, with a crimping tail.



**Table 18** Materials for preparing Ethernet Data Cables.

Marketing P/N	Description
N000082L016A	PTP 820 CAT5E Outdoor 100m drum
N000082L015A	PTP 820 CAT5E Outdoor 305m drum
N000082L014A	PTP 820 Glands_x5_KIT
N000082L017A	PTP 820 Grounding Kit for CAT5e F/UTP 8mm cable
N000082L073A	PTP 820 GBE_Connector_kit

To prepare the Ethernet cable and plug-in field:

- 1 Prepare the gland and insert the cable, as described in [General Installation Procedure](#) on page 4-15
- 2 Strip off approximately 45 mm of the outer insulation jacket from the CAT5E cable.
- 3 Do not strip off the end of the cable shield, but rather, twist the shield to form a braid.



- 4 Roll back the foil shield insulation and wrap the drain wire around the foil. Do not remove any insulation from the conductors.
- 5 Align the colored wires.

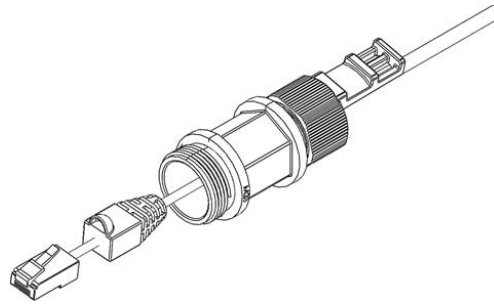
**Note**

Cord colors should be matched to the same pins on both ends of the cable


- 6 Trim all wires to the same length. About 12 mm on the left should be exposed from the inner sheath.
- 7 Separate the wires and place the twisted braid between the separated wires.



- 8 Insert the wires into the RJ45 plug. Verify that each wire is fully inserted into the front of the RJ45 plug and in the correct order, according to the pinouts shown in Section [Outdoor Ethernet Cable Specifications](#) on page 4-11. The sheath of the Ethernet cable should extend into the plug by about 13 mm and held in place by the crimp.
- 9 Extend the cable jacket with the shield into the connector about 5 mm for strain relief and shielding connection.



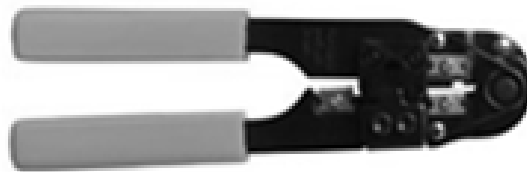
- 10 Wrap the twisted braid firmly around the cable jacket and let the crimping tail of the RJ45 plug envelop it.

 **Caution**  
To ensure proper grounding, it is essential that the twisted braid be firmly connected to the RJ45 plug.




Twisted Braid Enveloped by Crimping Tail

- 11 Crimp the RJ45 plug with the crimp tool. Make sure the twisted braid is crimped firmly to the RJ45 plug.



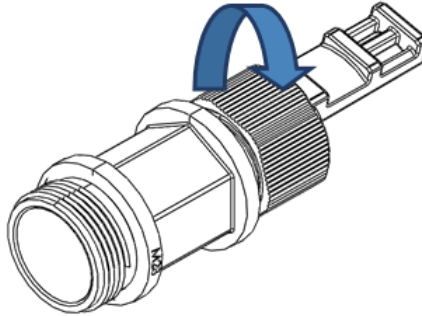
- 12 Verify that the wires ended up the correct order and that the wires extend to the front of the RJ45 plug and make good contact with the metal contacts in the RJ45 plug.
- 13 Push back the CAT5E plug cover on the connector plug.

 **Note**  
It is recommended that the newly prepared cable be tested with a Cable Analyzer such as the FLUKE DTX-1800 (or the equivalent), to make sure the cable complies with ANSI/TIA/EIA-568-B-2. Make sure to verify both connectivity and grounding continuity at both ends of the cable.

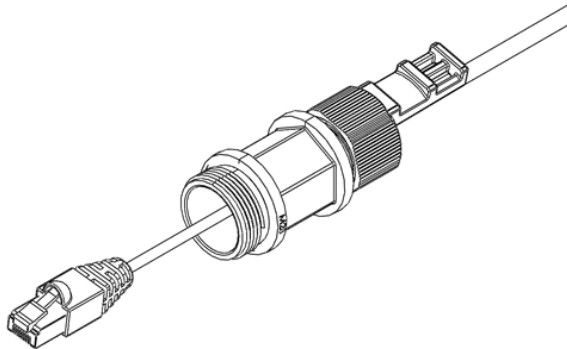
## Preparing the Ethernet Cable Already Assembled

To prepare the Ethernet cable already assembled:

- 1 Release the gland cap and the gland rubber slightly.



- 2 Insert the CAT5E cable into the gland cap and into the rubber gland.

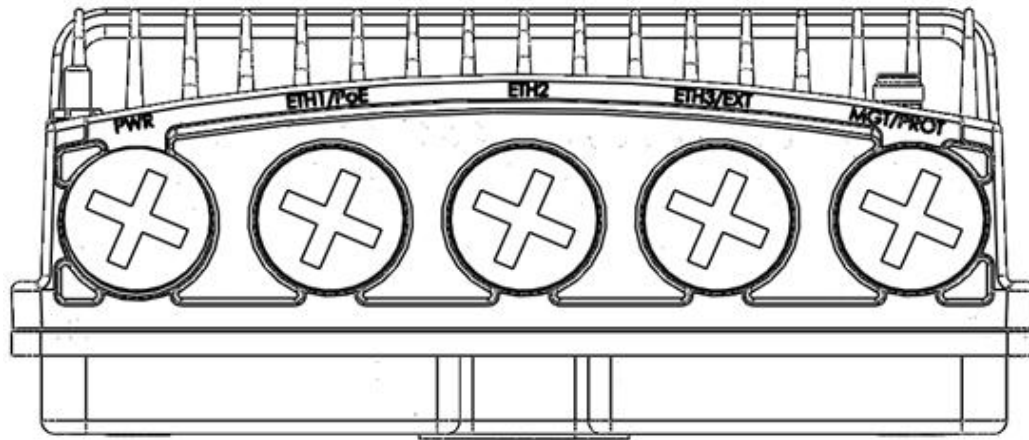


- 3 Insert the CAT5E cable into the gland body.

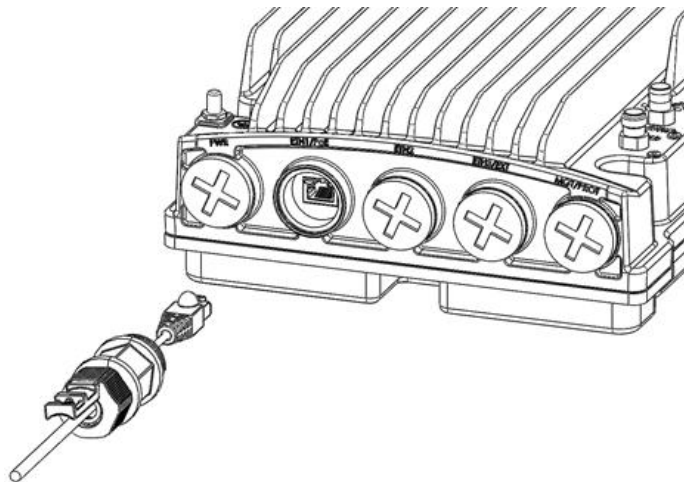
## Connection of Ethernet Cable to PTP 820S

To connect the Ethernet cable to the PTP 820S:

- 1 Remove the relevant cap from the PTP 820S radio. You can use the side of the gland to unscrew the cap.



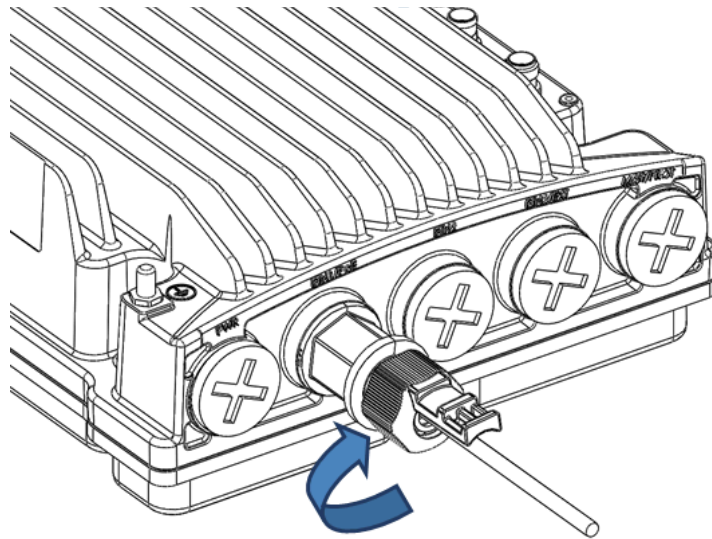
- 2 Connect the CAT5E cable to the PTP 820S.



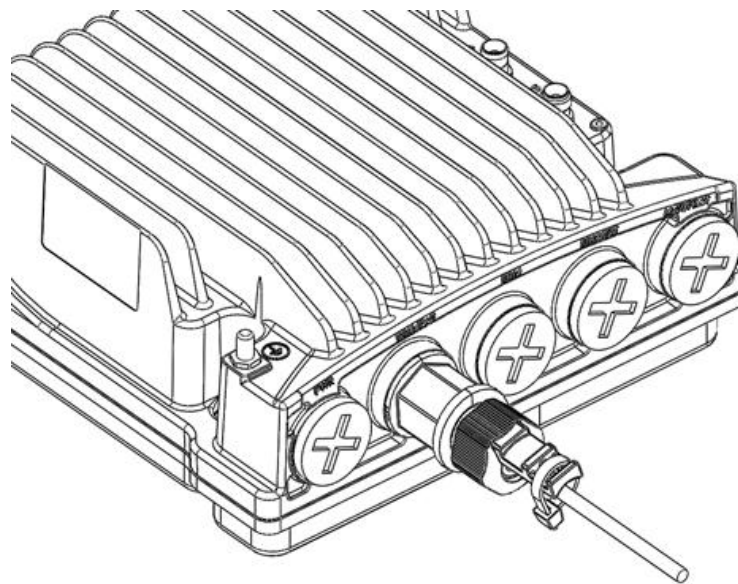
- 3 Screw the gland into the radio unit.

**Caution**

Before tightening the gland, make sure the gland is even with the cover. Tighten the gland gently and make sure there is no resistance. If there is resistance, stop immediately and verify that the gland is not being inserted at an angle. Tightening the gland at an angle can ruin the thread on the gland and prevent proper sealing of the interface.



- 4 Tighten the gland cap.
- 5 Secure the cable to the gland using a tie wrap.





# Management Connection for 1+1 HSB Configurations

In HSB protection configurations, two Y-splitter cables and a special signaling cable must be used to connect the management ports (MGT/PROT) of the two PTP 820S units and provide management access to each unit.

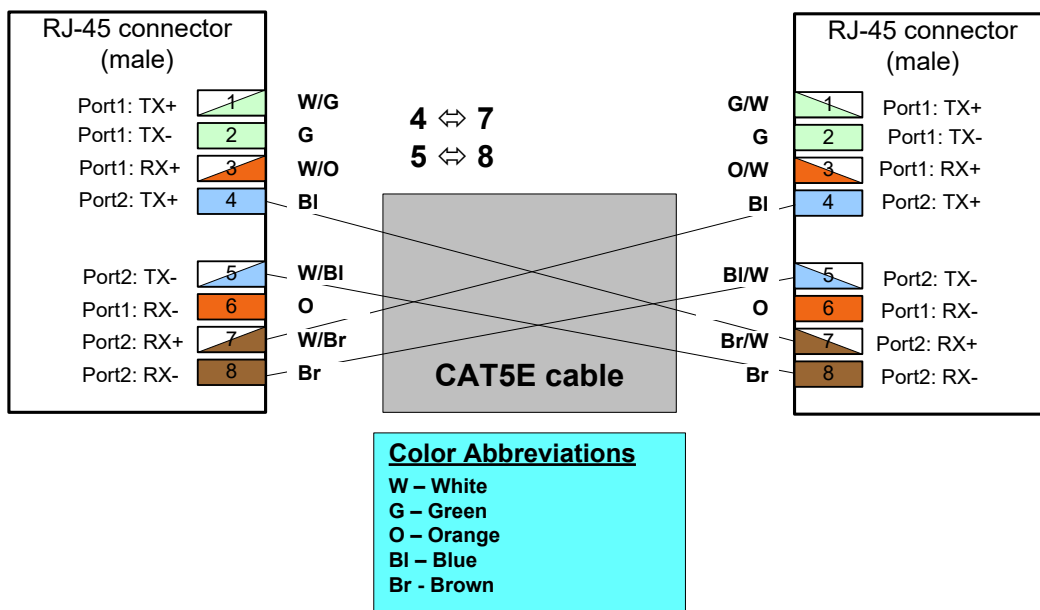
The Protection signaling cables are available pre-assembled from Cambium in various lengths, but users can also prepare them in the field.

The following sections explain how to prepare and connect these cables.

## Preparing a Protection Signaling Cable

The Protection signaling cables require the following pinouts.

**Figure 11** Protection Signaling Cable Pinouts



**Note**

Other than the pinout connection described above, the cable should be prepared according to the cable preparation procedure described in [Connecting the Ethernet Cable](#) on page 4-27.

## Connecting the Protection Splitters and Protection Signaling Cable

Each splitter has three ports:

- System plug (“Sys”) – The system plug should be connected to the PTP 820S’s management port.
- Management port (“Mng”) – A standard CAT5E cable should be connected to the splitter’s management port in order to utilize out-of-band (external) management.

**Note**

Even for systems that use in-band management, initial configuration of an HSB protection configuration must be performed manually using out-of-band management.

- Protection signaling port (“Prot”) – A Protection signaling cross cable, as described above, should be connected between this port and the other “Prot” port of the second splitter on the mate PTP 820S unit.

---

# Chapter 5: PoE Injector Installation and Connection

---

This chapter describes the PTP 820S PoE Injector installation and connection procedure.

This chapter includes:

- [PoE Injector Cable Connection](#)
- [PoE Injector Grounding](#)
- [PoE Injector Wall Mount Installation](#)
- [PoE Injector 19" Rack Installation](#)
- [PoE Injector ETSI Rack Installation](#)

# PoE Injector Cable Connection

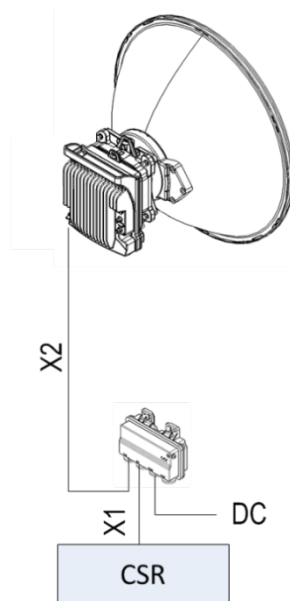
The PoE Injector cables are connected similar to the PTP 820S.

- To connect the Ethernet (CAT5E) cable to the PoE or Data port, see [Connection of Ethernet Cable to PTP 820S](#) on page 4-31.
- To connect the DC power cable to the power port or dual feed port, see [Connecting a DC Power Cable](#) on page 4-24.
- The total length of the cable between the PTP 820S port and the Switch/Router the device is connected to must not exceed 100m/328ft. This length includes the connection between the PTP 820S and the PoE Injector ( $X1 + X2 \leq 100\text{m}/328\text{ft}$  in the figure below).

**Note**

The length of the cable connecting the customer equipment to the PoE injector should not be longer than 10m (according to ANSI/TIA-568 standard).

**Figure 12** PoE Injector cable connection

**Note**

For the warranty to be honored, the connection must be through the glands only. Do not open the PoE injector box cover.

# PoE Injector Grounding

---

To ground the PoE Injector:

- On the right side of each PoE Injector, loosen the screw, plain washer and serrated washer.
- Place the cable lug (supplied with the PoE injector kit) between the plain and serrated washer.
- Tighten the screw.
- Perform a resistance test between the 2 lugs of the GND cable. Verify that the result is 0-2 ohms.

# PoE Injector Wall Mount Installation

## List of Items

**Table 19** Required items for Wall Mount PoE Injector

Item	Description	Quantity	Remarks
1	PoE Injector	1	

## Required Tools

- Metric offset wrench key wrench set
- Hammer
- Drilling Machine

## Procedure

- 1 Mount and tighten the PoE Injector to a wall using two M6 bolts and anchors. The M6 bolts and anchors must be purchased separately.

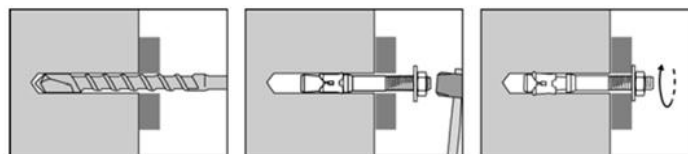


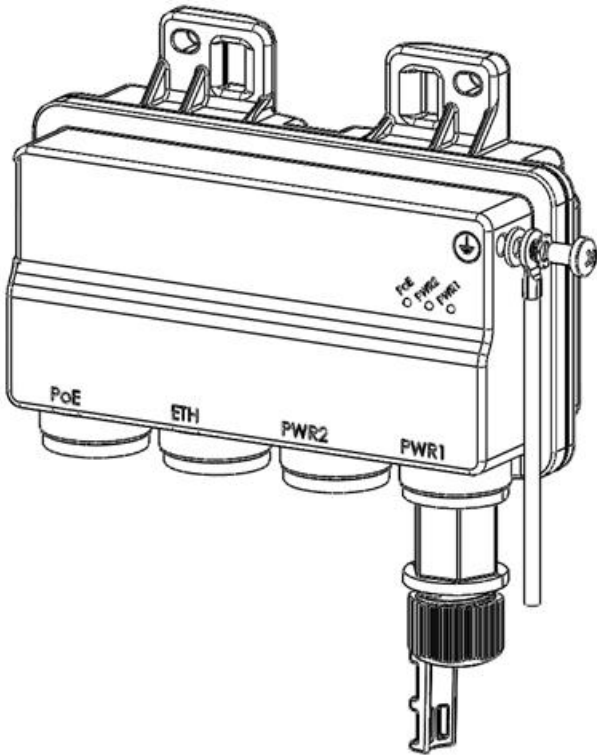
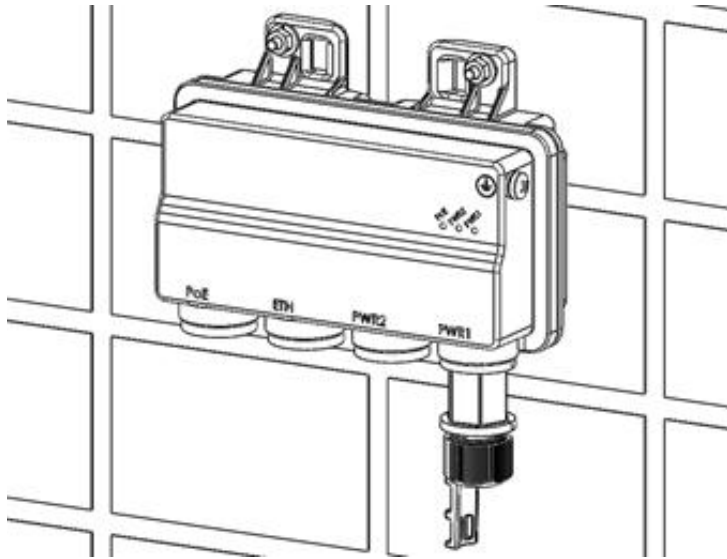
**Note**

Use anchor stainless steel with flanged hexagonal nut M6X70.

- 2 Drill two 6mm diameter holes with 100mm distance between the center of the holes.
- 3 Insert the anchors with the bolts.
- 4 Place the washers on the bolt.
- 5 Tighten the nuts.

**Figure 13** PoE Injector Wall Mount Installation





# PoE Injector Pole Mount Installation

---

## List of Items

Item	Description	Quantity	Remarks
1	PoE Injector	1	

## Required Tools

- Slot Screwdriver

## Procedure

To mount the PoE Injector on a pole:

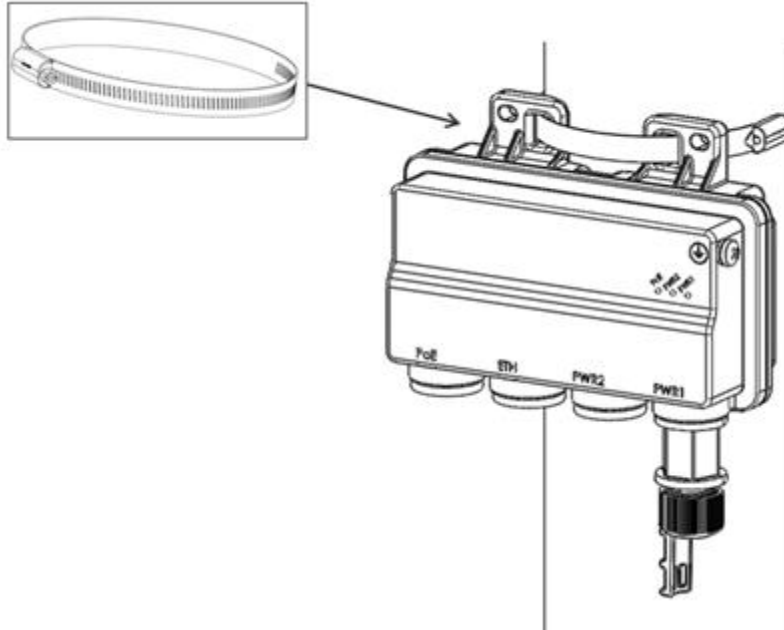
1. Mount and tighten the PoE Injector to a pole with a diameter of 114 mm using a stainless steel hose clamp.
2. Pass the hose clamp through the pole mount slots.



**Note:** The Hose Clamp is not supplied with PoE injector kit.

3. Attach the PoE injector to the pole.
4. Connect the ends of the hose clamp.
5. Tighten the hose clamp using the captive screw.





**Figure 14 PoE Injector Pole Mount Installation**

# PoE Injector 19" Rack Installation

## List of Items

**Table 20** Required item for 19" Rack Installation PoE Injector

Item	Description	Quantity	Remarks
1	PoE Injector	1	
2	PoE Injector 19" Rack Mount KIT	1	

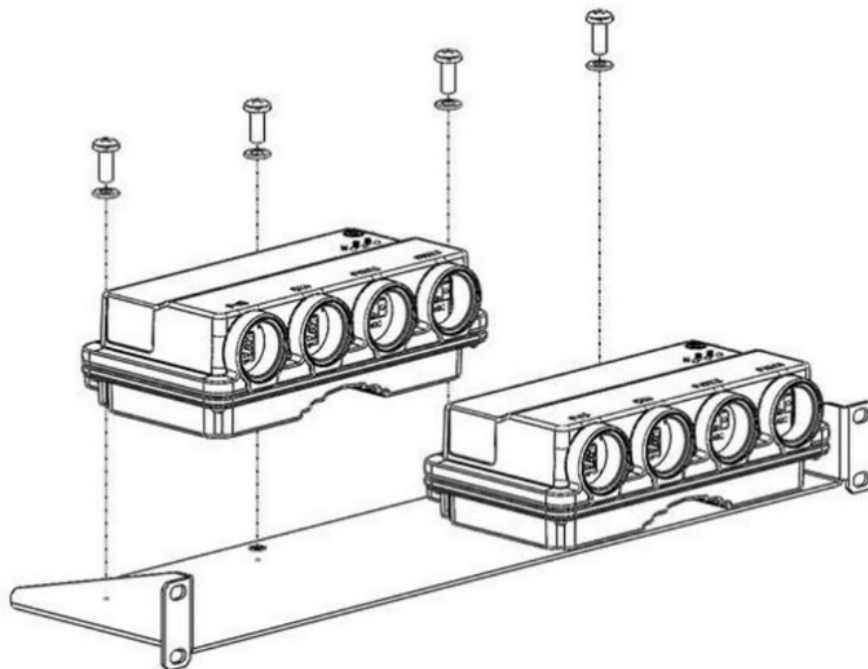
## Required Tools

- Philips Screwdriver

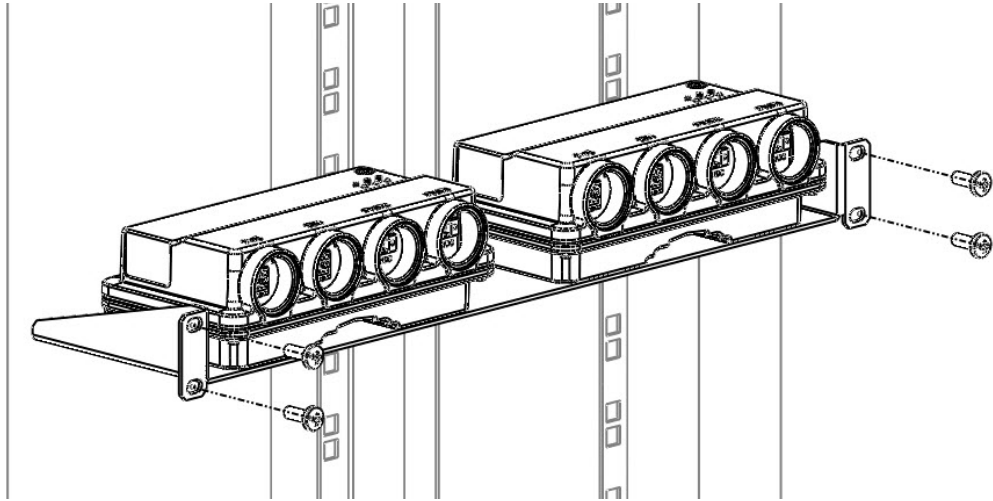
## Procedure

To mount the PoE Injector on a rack:

- 1 Mount the PoE Injector to a 19" rack using a 19" rack adaptor.
- 2 Mount the PoE Injector on the 19" adaptor through the wall mounting holes, using M6 screws and washers.



- 3 Mount the 19" rack adaptor to a 19" rack using four M6 screws and cage nuts.



# PoE Injector ETSI Rack Installation

---

## List of Items

**Table 21** Required items PoE Injector ETSI Rack

Item	Description	Quantity	Remarks
1	PoE Injector	1	
2	PoE Injector ETSI Rack Mount KIT	1	

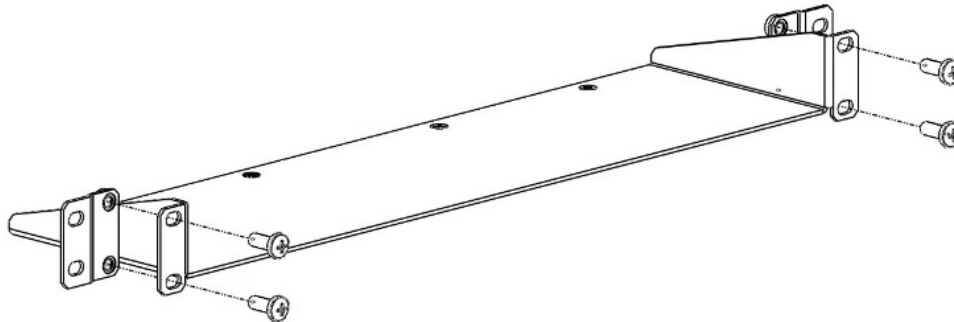
## Required Tools

- Philips Screwdriver

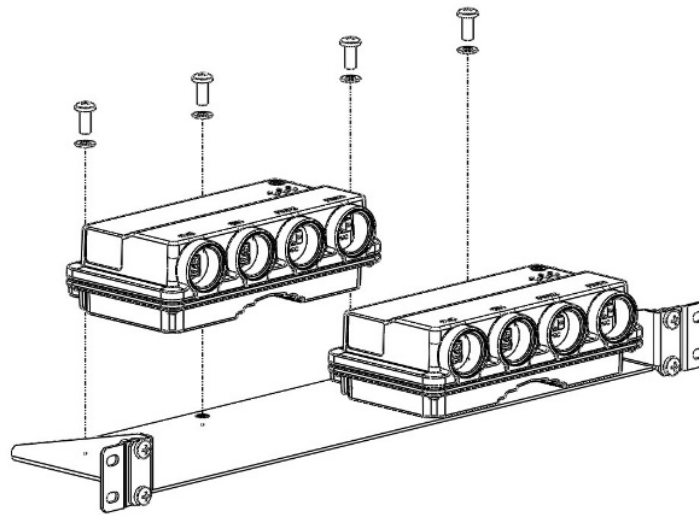
## Procedure

To mount the PoE Injector to an ETSI rack:

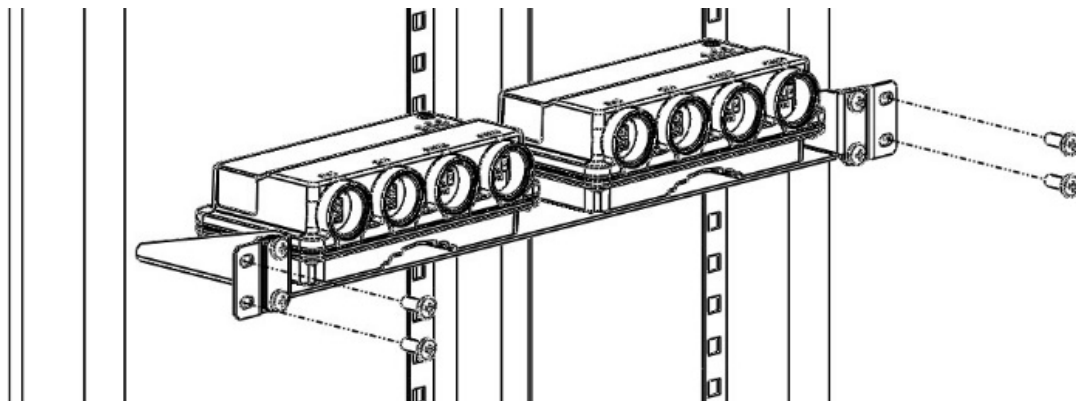
- 1 Mount the PoE Injector to an ETSI rack using a 19" rack adaptor and ETSI-adapting ears.
- 2 Connect the ETSI adapting ears to a 19" rack adaptor using four M6 screws.



- 3 Mount the PoE Injector on the adaptor through the wall mounting holes using M6 screws and washers.



- 4 Mount the 19" rack adaptor with the ETSI ears on the ETSI rack using four M6 screws and cage nuts.

**Note**

For this type of installation, a 2RU space is required.

---

# Chapter 6: Generic Installation Procedures and Notes

---

This chapter describes the generic installation procedure and notes for PTP 820S.

This chapter includes:

- [Torque Requirements](#)
- [Pole Mount Installation](#)

# Torque Requirements

---

When tightening the captive screws, use 20 Nm torque for radio-antenna, radio-mediation device, and mediation device-antenna connections. In order to avoid misalignment, screws should be tightened progressively.

When fastening a waveguide to the radio or mediation device, use the following torque, according to frequency and screw type:

- 6 GHz: M5/#10-32: 3.5 Nm
- 7/8-15 GHz: M4/#8-32: 2.5 Nm
- 18-42 GHz: M3/#4-40: 1Nm

# Pole Mount Installation

The pole diameter range for pole mount installations is 8.89 cm – 11.43 cm (3.5 inches – 4.5 inches).

## PTP 820S DC Pole Mount Procedure

### List of Items

**Table 22** Required items for 1+1 Direct Mount configuration

Item	Description	Quantity	Remarks
1	PTP 820S DC Pole Mount KIT	1	

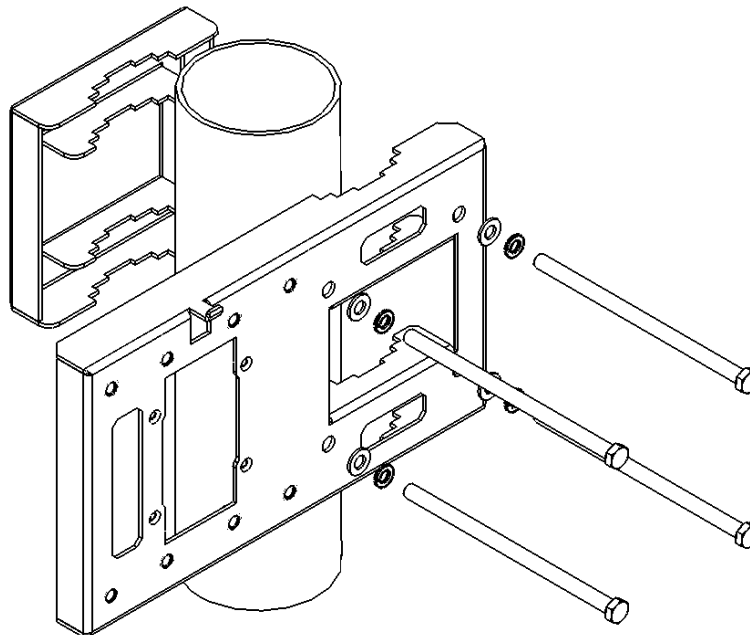
### Required Tools

- Metric offset wrench key wrench set

### Procedure

- 1 Mount and tighten the PTP 820S DC pole mount to a pole with a diameter of 114 mm using the four washers and screws supplied with the PTP 820S DC pole mount kit.

**Figure 15** Mount PTP 820S DC Pole Mount to Pole





---

# Chapter 7: PTP 820S Detailed Configurations Description

---

This chapter describes the PTP 820S detailed configuration description.

This chapter includes:

- [1+0 Direct Mount Installation](#)
- [2+0 Dual Polarization Direct Mount](#)
- [2+0 Dual Polarization Remote Mount](#)
- [1+1HSB/2+0 Single Polarization Direct Mount](#)
- [1+1HSB/2+0 Single Polarization Remote Mount](#)

# 1+0 Direct Mount Installation

---

## List of Items

**Table 23** Required items for 1+1 Direct Mount configuration

Item	Description	Quantity	Remarks
1	PTP 820S Radio	1	

## Required Tools

The following tools are required for the PTP 820S installation:

- Metric offset hexagon key wrench #6
- Phillips #2 screwdriver

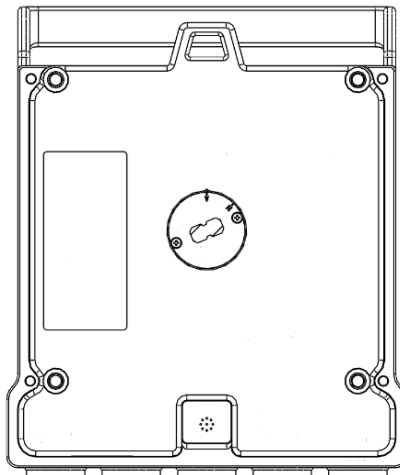
## Procedure

- 1 To install the PTP 820S in a direct mount 1+0 configuration:



**Caution**

Do not remove the transparent pressure window located on the antenna interface.

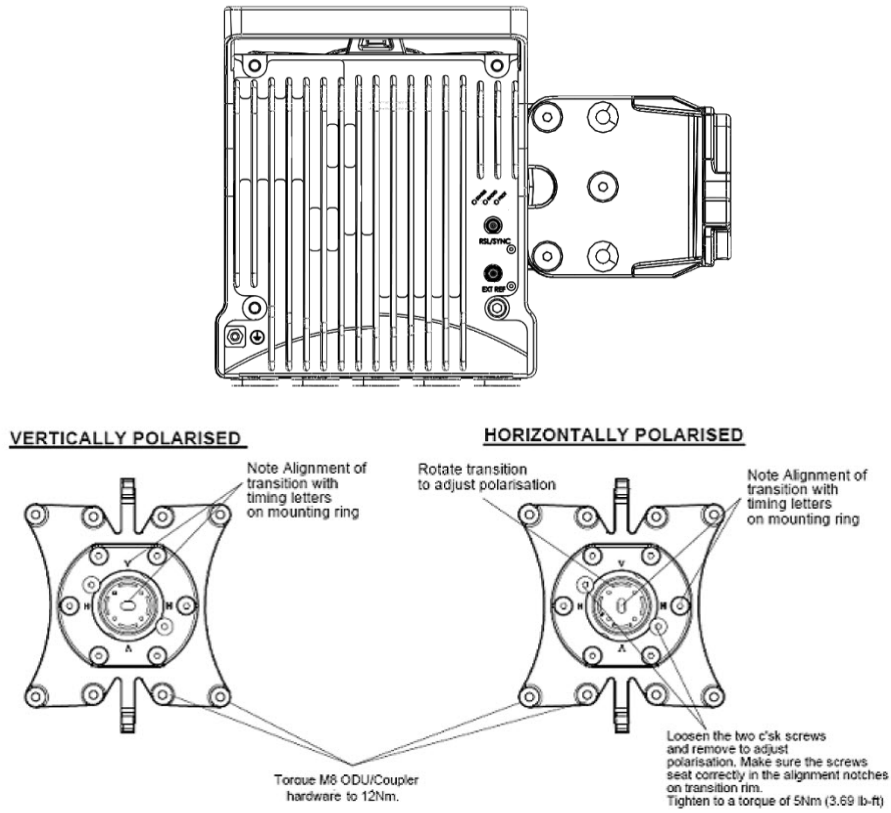




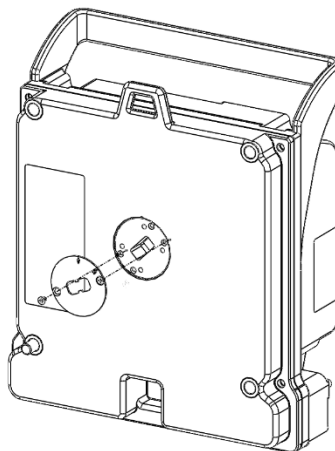
**Note**

If necessary, change the antenna polarization by rotating the unit in accordance with the relevant antenna installation guide.

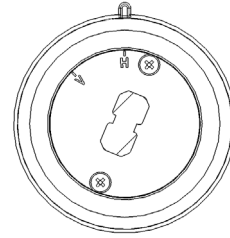
**Figure 16** Horizontal / Vertical Pole



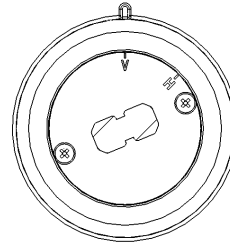
**Figure 17** Twist orientation



- 1 For horizontal polarization, locate the holes above and below the letter “H” on the pins and fasten the two screws.



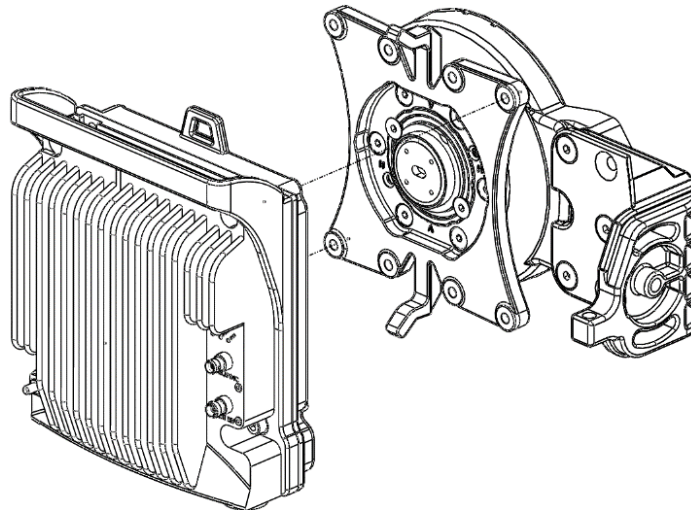
For vertical polarization, locate the holes above and below the letter “V” on the pins and fasten the two screws.



**Note**

For 6 GHz, separate irises are used for vertical and horizontal polarization. The vertical iris comes assembled with the PTP 820S. The horizontal iris (MA-1840-X, PTP 820S Twist 6Ghz Horizontal) is included in the PTP 820S.

- 2 Mount the PTP 820S on the antenna using the four M8 captive screws and washers that are supplied and tighten the screws.

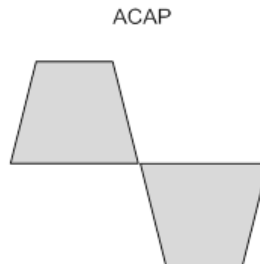


**Note**

Make sure the polarization mounting direction of the PTP 820S is correct.

## 2+0 Dual Polarization Direct Mount

**Figure 18** 2+0 Dual Polarization Direct Mount



**Note**

This procedure can also be used for 1+0DP HW ready for 2+0 DP configuration.

### List of Items

**Table 24** Required items for 2+0 Dual polarization direct mount configuration

Item	Description	Quantity	Remarks
1	PTP 820S Radio	2	
2	RFU-C OMT KIT	1	

### Required Tools

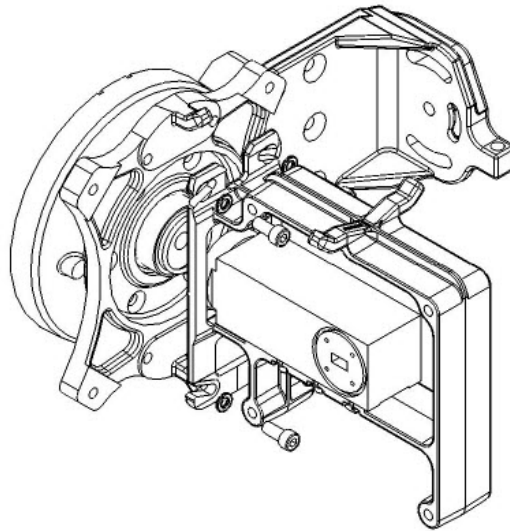
- Metric offset hexagon key set
- Metric wrench key set

### Procedure

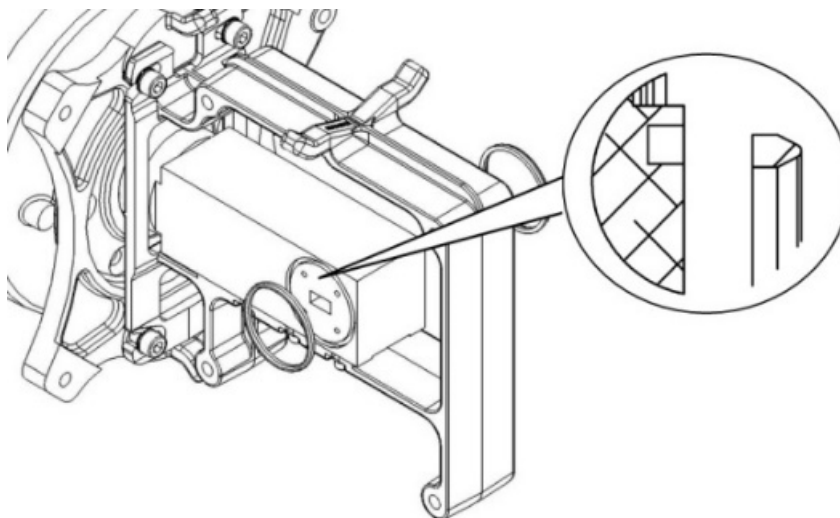
- 1 Prior to the installation, follow the antenna manufacturer's instructions to use the circular adaptor. (Remove the existing rectangular transition, swap the O-ring, and install the circular transition instead.).



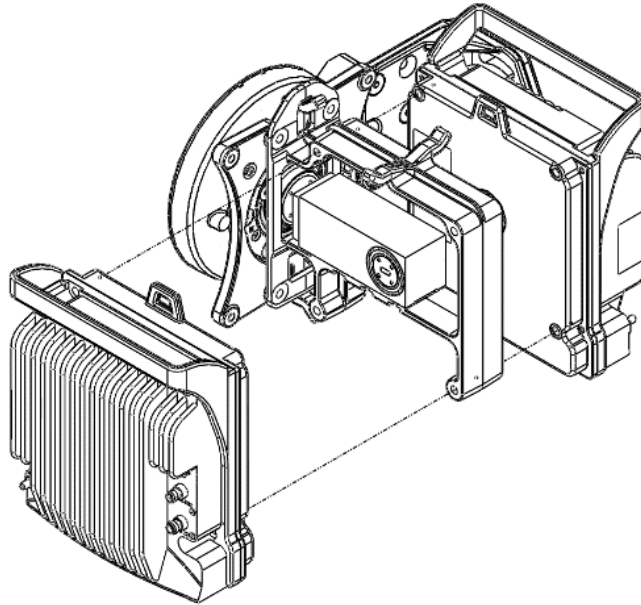
- 2 Connect the RFU-C OMT Kit to the antenna and secure it with four screws. Verify the existence of the O-ring.



- 3 Mount the two O-Rings supplied with the RFU-C OMT kit on the OMT body. Make sure the mounting direction is correct, as shown in the section view.



- 4 Mount both RFUs, using the four M8 captive screws and washers supplied, through the radio and OMT holder, and tighten the screws. Make sure the polarization mounting direction is correct.



- 5 Tilt the entire assembly, as described in the dual polarization link alignment procedure, to achieve maximum XPD (Cross Polar Differentiation). After link alignment, tighten the four M8 screws left open in step 2 above.

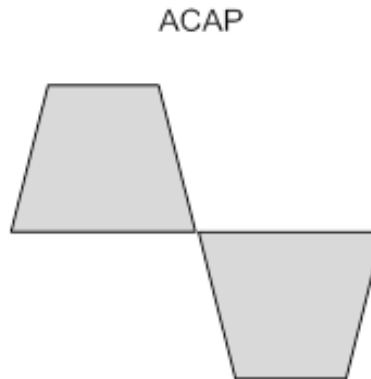
## 2+0 Dual Polarization Remote Mount



### Note

This procedure can also be used for 1+0DP HW ready for 2+0 DP configuration.

**Figure 19** 2+0 Dual Polarization Remote Mount



## List of Items

**Table 25** Required items for 2+0 Dual polarization direct mount configuration

Item	Description	Quantity	Remarks
1	PTP 820S Radio	1	
2	RFU-C OMT KIT	1	
3	FLEXIBLE WG KIT	2	
4	RFU-C Pole Mount KIT	1	
5	RFU-C Remote Mount Adaptor KIT	1	From 6-13GHz

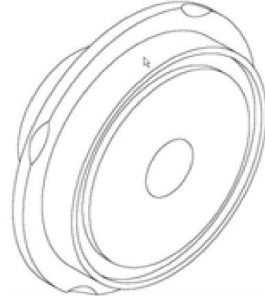
## Required Tools

- Metric offset hexagon key set
- Metric wrench key set
- Phillips #1, #2 screwdriver

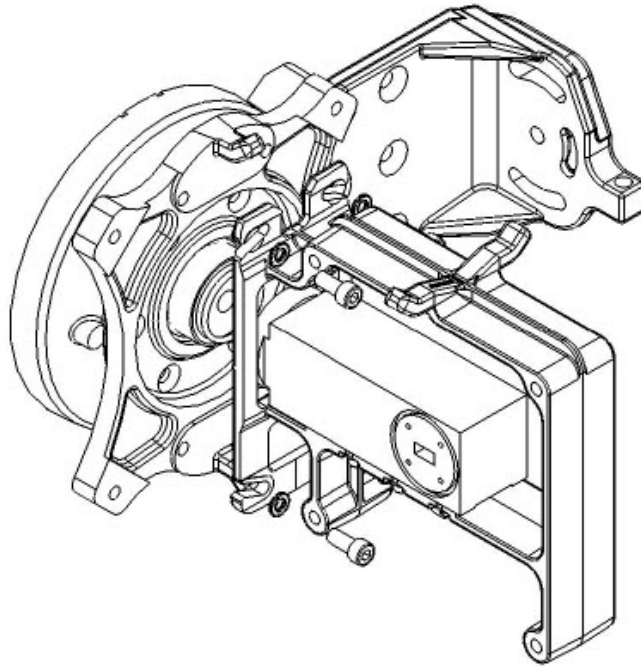


## Common Installation Procedures

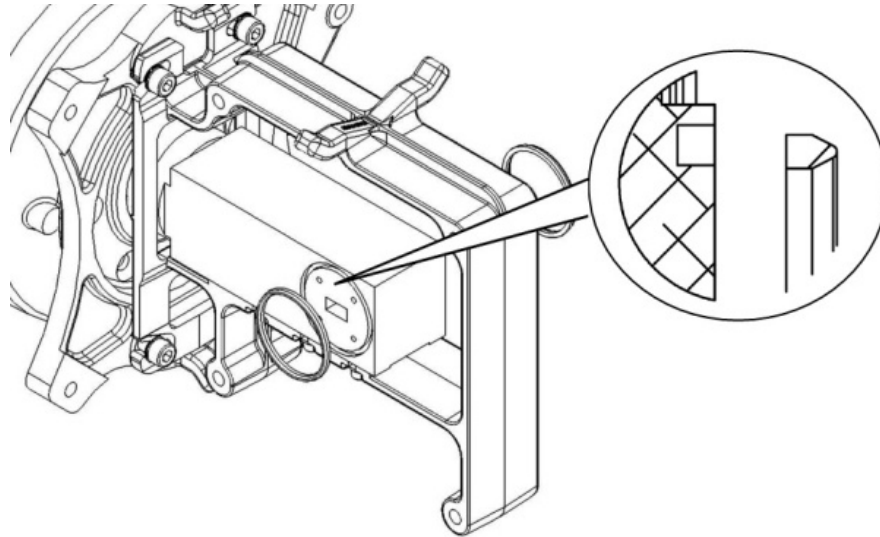
- 1 Prior to the installation, follow the antenna manufacturer's instructions to use the circular adaptor. (Remove the existing rectangular transition, swap the O-ring, and install the circular transition instead.)



- 2 Connect the RFU-C OMT Kit to the antenna and secure it with four screws. Verify the existence of the O-ring.

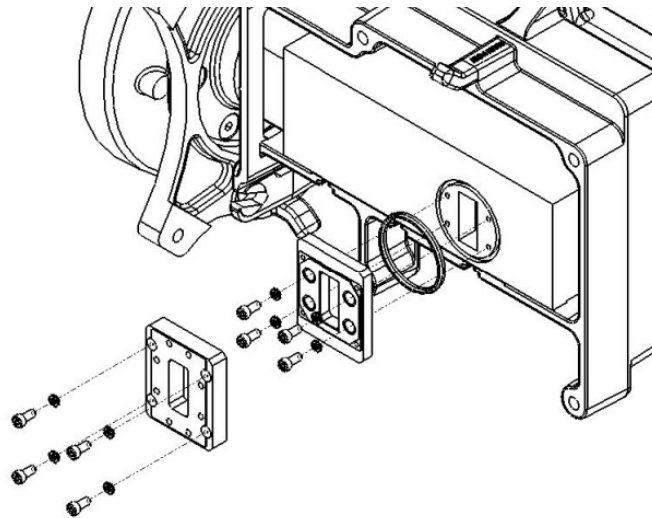


- 3 Mount the two O-Rings supplied with the RFU-C OMT kit on the OMT body. Make sure the mounting direction is correct, as shown in the section view.



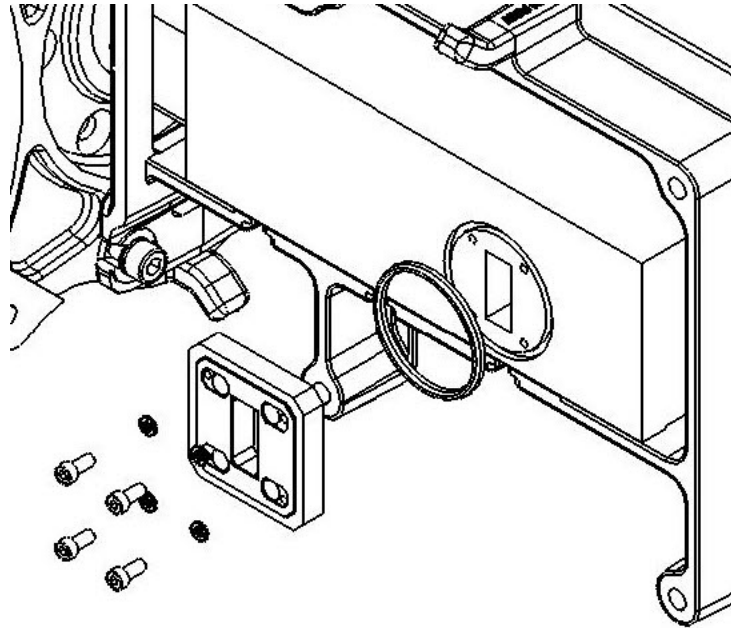
This procedure is applicable for all remote mount configurations that involve an OMT.

- 1 For 6GHz (UDR70):
  - i Mount the O-Ring supplied with the OMT kit.
  - ii Mount OMT Adaptor #1 on the OMT, and tighten using four M4 screws and washers (supplied with the OMT adaptor kit).
  - iii Mount OMT Adaptor #2 on OMT Adaptor #1, and tighten using four M4 screws and washers (supplied with the OMT adaptor kit).

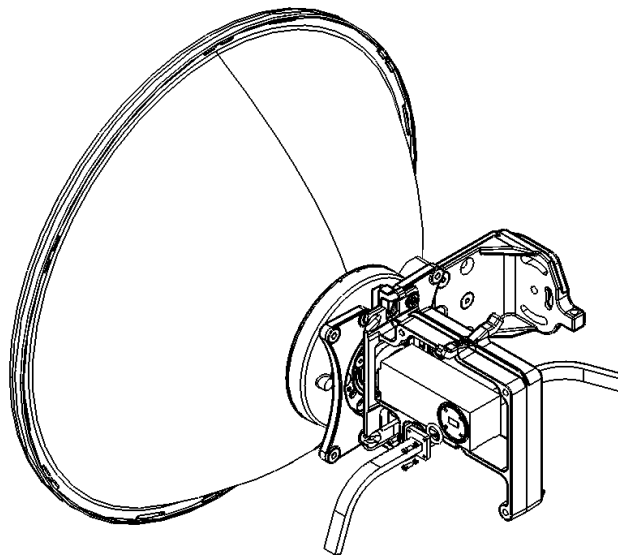


- iv Mount the flexible waveguide as usual.
- 2 For 7-11 GHz (UBR84 and UBR100):
  - i Mount the O-Ring supplied with the OMT kit.

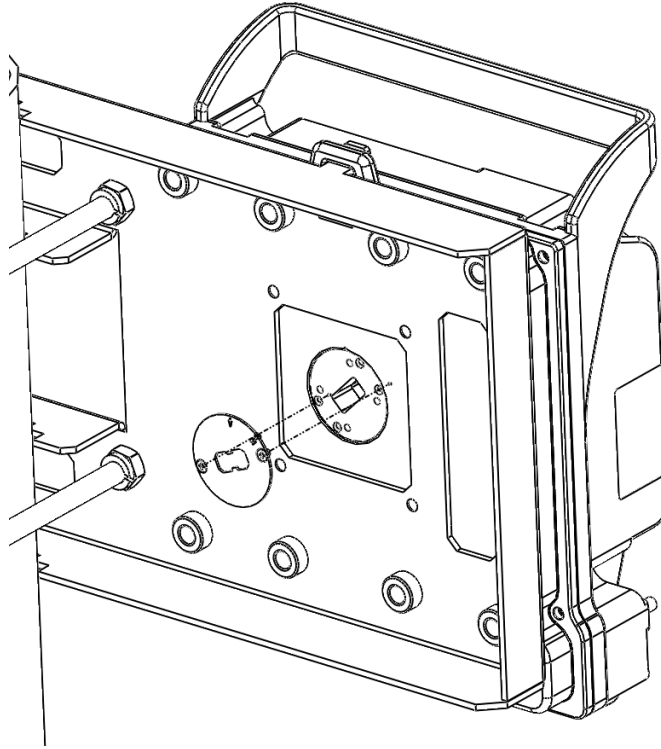
- ii Mount the OMT adaptor, with its installed sealing gasket, on the OMT, and tighten using the four M4 screws and washers supplied with the OMT Adaptor kit.



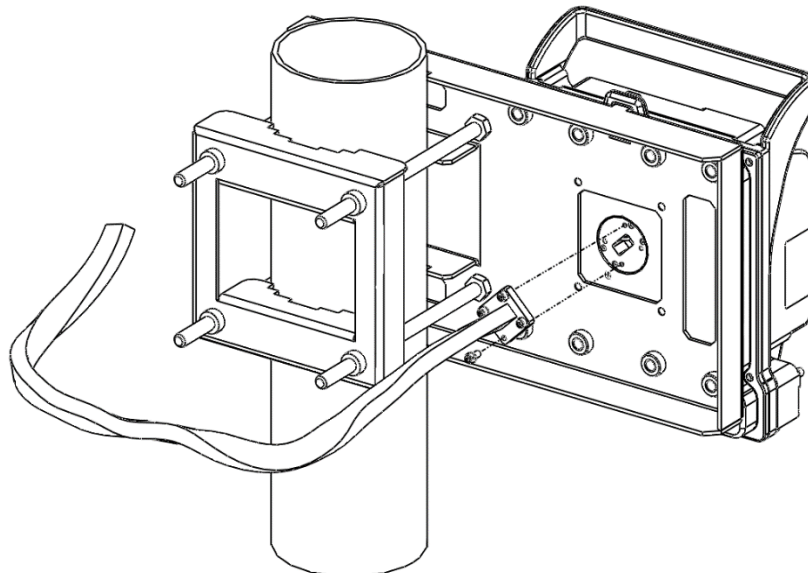
- iii Mount the flexible waveguide without its gasket (only for the OMT side).
- 3 For 13 GHz (UBR120) to 38 GHz (UG383/U), connect the flexible waveguide and its gasket (supplied with the Flexible WG Kit) directly to the OMT port.



- 4 Loosen the 2 screws, and remove the twist.



- 5 Mount the PT 820S Radio to RFU-C Pole Mount Bracket using the four captive screws and washers supplied, assembled, in the PTP 820S.
- 6 Connect the Flexible Waveguide and sealing O-Ring supplied with the Flexible Waveguide Imperial kit. Tighten the four metric screws supplied with the RFU-C Adaptor kit.

**Note**

Remote Configuration Frequencies 13-38 GHz do not require adaptors.

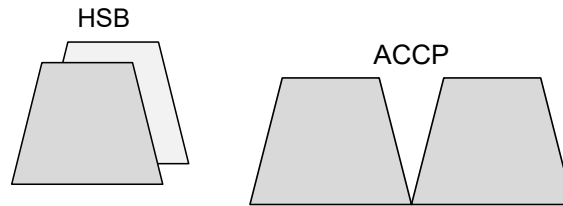
---

Frequencies 6-13 GHz require remote mount adaptors.

---

# 1+1HSB/2+0 Single Polarization Direct Mount

**Figure 20** 1+1HSB/2+0 Single Polarization Direct Mount



**Note**

This procedure can also be used for 1+0SP HW ready for 2+0 SP configuration.

## List of Items

**Table 26** Required items for 1+1HSB/2+0 Single Polarization Direct Mount configuration

Item	Description	Quantity	Remarks
1	PTP 820S Radio	2	
2	RFU-C Coupler/Splitter KIT	1	For 1+1HSB configuration, a coupler must be used
3	RFU-C Twist KIT	1	

## Required Tools

The following tools are required for the installation:

- Metric offset hexagon key wrench #6
- Phillips #2 screwdriver
- Metric offset hexagon key wrench #2.5 and #3

## Procedure

In 1+1 direct mount installation, the PTP 820S is attached to a coupler. To install a PTP 820S in a direct mount 1+1 configuration:

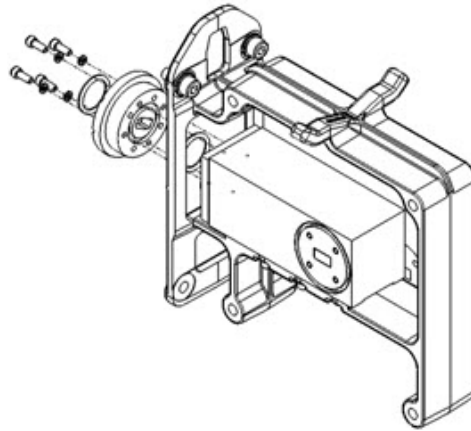


**Note**

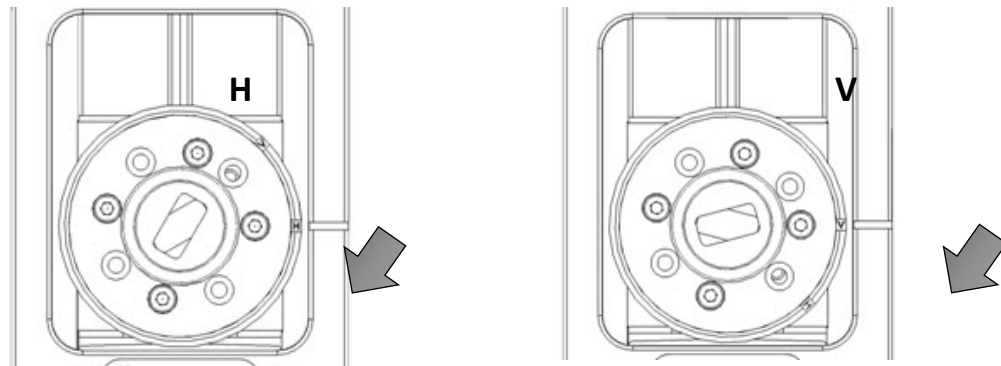
For 15 and 18 GHz frequencies, two O-Rings are supplied in the Twist kit and must be mounted in the twist grooves.

For 6 GHz frequency, a gasket is used instead of an O-Ring. The gasket must be mounted between the twist and the RFU-C Coupler kit.

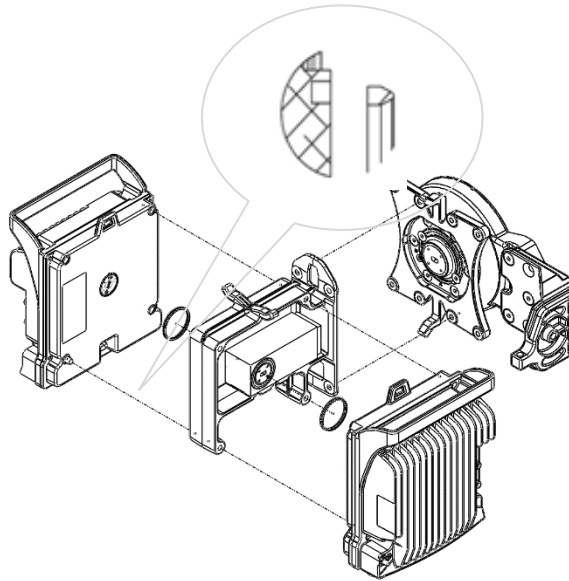
- 1 Mount the twist to the coupler using the O-Ring and four screws supplied in the Twist kit and tighten the screws.

**Caution**

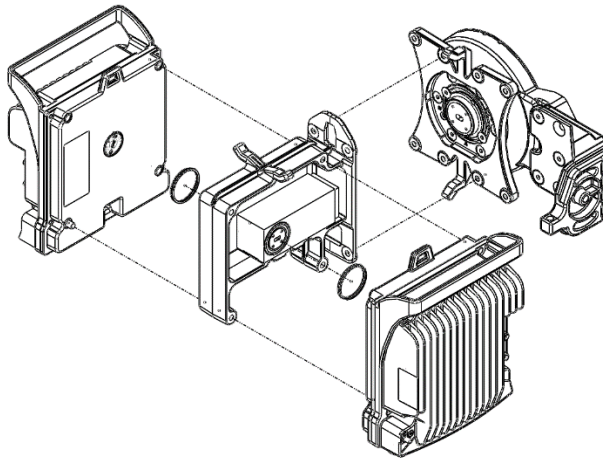
Make sure the polarization mounting direction of the twist to the coupler is according to the antenna polarization.



- 2 Mount the coupler radio on the antenna using the four M8 screws and washers supplied with the RFU-C Coupler kit and tighten the screws.
- 3 Mount the two O-Rings supplied with the RFU-C Coupler kit, as shown in the following figure.



- 4 Mount the PTP 820S to the body of the coupler using the four M8 captive screws and washers that are supplied and tighten the screws.





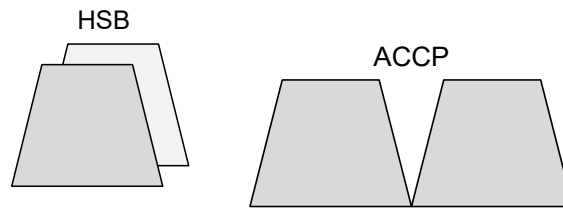
# 1+1HSB/2+0 Single Polarization Remote Mount



## Note

This procedure can also be used for 1+0SP HW ready for 2+0SP configuration.

**Figure 21** 1+1HSB/2+0 Single Polarization Remote Mount



## List of Items

**Table 27** Required items for 1+1HSB/2+0 Single Polarization Remote Mount configuration

Item	Description	Quantity	Remarks
1	PTP 820S Radio	1	
2	RFU-C Pole Mount KIT	1	
3	RFU-C Coupler/Splitter KIT	1	For 1+1HSB configuration, a coupler should be used
	FLEXIBLE WG Metric KIT	1	

## Required Tools

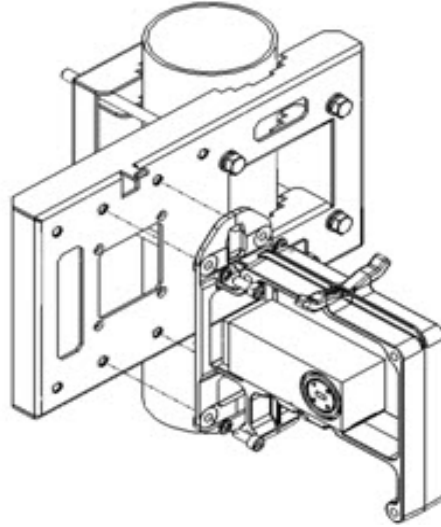
The following tools are required for the installation:

- Metric offset hexagon key wrench #6
- Phillips #2 screwdriver
- Metric offset hexagon key wrench #2.5 and #3

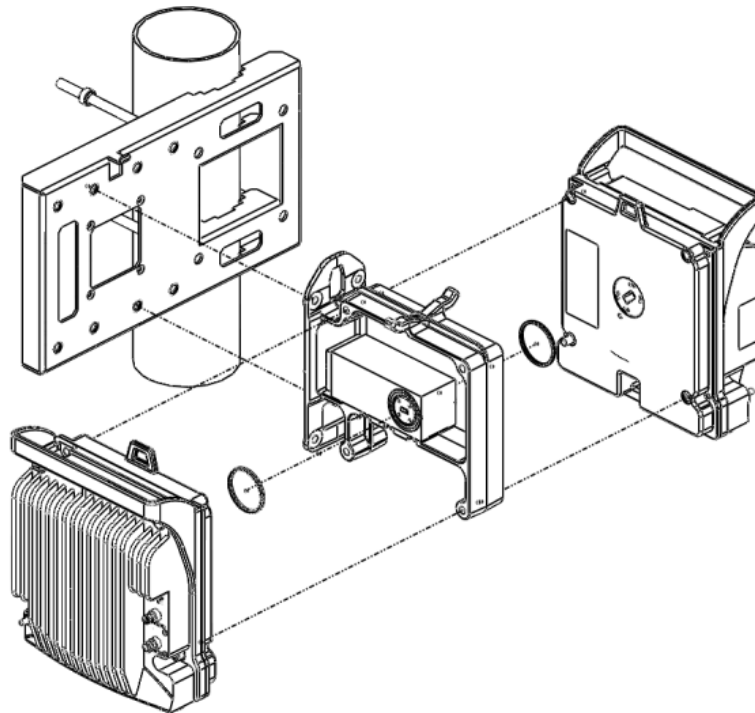
## Procedure

In 1+1 remote mount installation, the PTP 820S radios are attached to a coupler, while the coupler is connected to the antenna via flexible WG. To install the PTP 820S in a remote mount 1+1 configuration:

- 1 Mount the RFU-C coupler to the RFU-C pole mount bracket using the four M8 screws and washers supplied with the RFU-C Coupler kit, and tighten the screws.



- 2 Mount the two O-Rings supplied with the Coupler kit, according to the Coupler kit instructions.

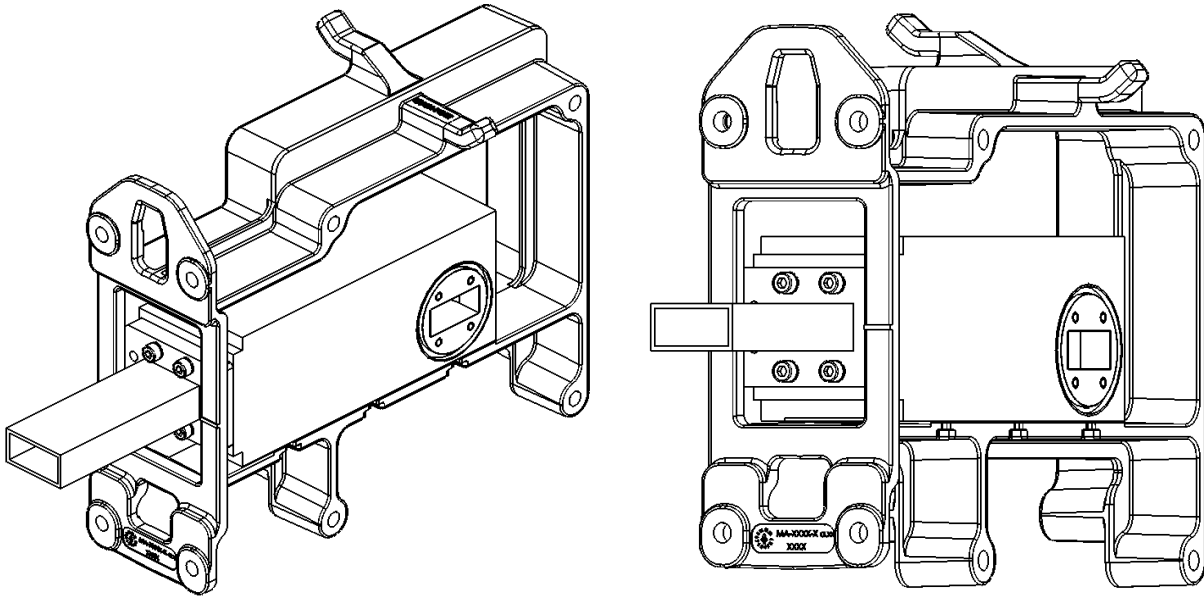


- 3 Mount the PTP 820S radio to the body of the coupler using the four M8 captive screws and washers that are supplied, assembled, in the PTP 820S, and tighten the screws.

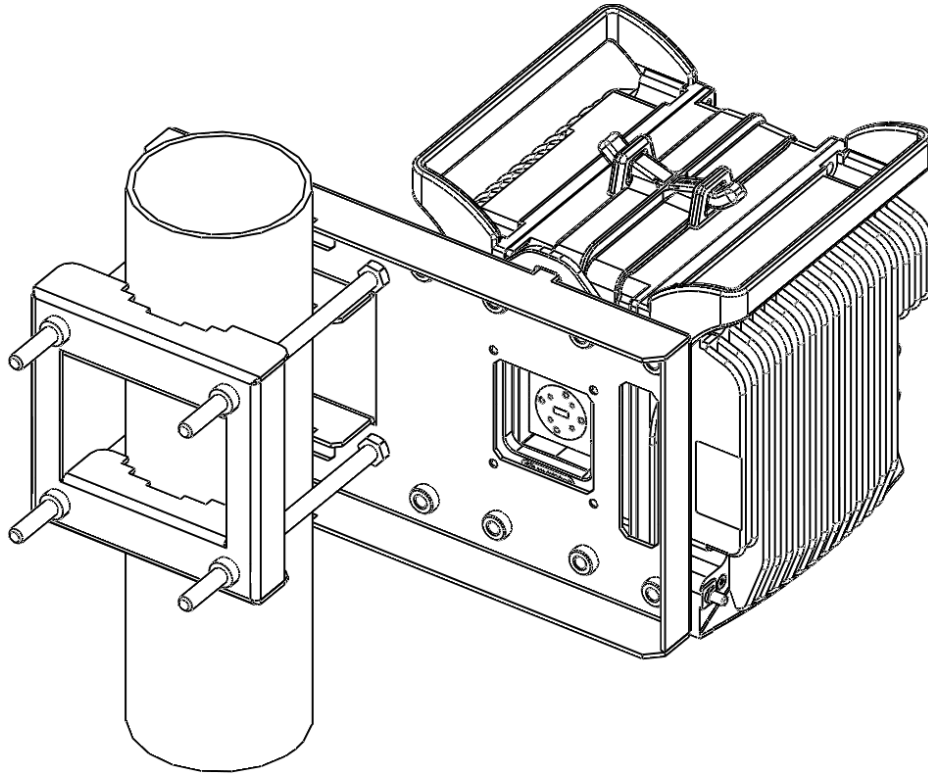
- 4 Place the O-Ring in the flexible waveguide flange groove.
- 5 Mount the flexible waveguide on the coupler, and tighten the screws and washers.

**Note**

For 6 GHz, only 4 screws should be used, as shown in the following figures.



- 6 Place the O-Ring in the other end of the flexible waveguide flange groove.
- 7 Mount the flexible waveguide on the antenna, and tighten the screws and washers.



## Mediation Device Losses

**Table 28** PTP 820S Mediation Device Losses

Configuration	Interfaces		6 – 8 GHz	11 GHz	13 – 15 GHz	18 – 26 GHz	28 – 38 GHz
Flex WG	Remote Mount antenna	Added on remote mount configurations	0.5	0.5	1.2	1.5	1.5
1+0	Direct Mount	Integrated antenna	0.2	0.2	0.4	0.5	0.5
OMT	Direct Mount	Integrated antenna	0.3	0.3	0.3	0.5	0.5
Splitter	Direct Mount	Integrated antenna	3.3	3.4	3.4	3.4	3.5



**Note**

The antenna interface is always the PTP 820S interface.

If other antennas are to be used, an adaptor with a 0.1 dB loss must be considered.

The numbers above represent the typical loss per component.

---

# Chapter 8: Acceptance and Commissioning Procedures

---

This chapter provides Cambium's recommended Acceptance and Commissioning Procedure for PTP 820. Acceptance and commissioning should be performed after initial setup is complete.

The purpose of this procedure is to verify correct installation and operation of the installed link and the interoperability with customer end equipment.

Cambium's Acceptance and Commissioning procedure includes the following stages:

- Site Acceptance Procedure
- Commissioning of Radio Link

The Site Acceptance Procedure is a checklist that summarizes the installation requirements of the site at which the products were installed.

The commissioning tests cover the required configuration information that should be recorded, and the tests that should be performed on the radio link.

# Site Acceptance Procedure

The purpose of the following procedures is to verify that all installation requirements were noted and checked.

Following this procedure will ensure proper, long-lasting, and safe operation of the product.

The checklist below summarizes the installation requirements of the site.

<b>SITE ACCEPTANCE CHECKLIST</b>	
<b>1. SITE INFORMATION</b>	
Customer:	
Radio model:	
Site name:	
Site code:	
Radio link code:	
Site address:	
<b>2. ANTENNA MOUNTING</b>	
Antenna mount type:	
Mount is of sufficient height to clear local obstructions	OK
Mount is safely positioned to not cause a safety hazard	OK
Mount is secure and perpendicular	OK
Mount is grounded as per site specifications	OK
All steelwork is Galvanized or Stainless Steel as appropriate	OK
<b>3. ANTENNA</b>	
Antenna type (model and size):	
Antenna is securely fixed to mount	OK
Antenna is grounded as per site specifications	OK
Antenna sway braces are installed correctly (where applicable)	OK
Antenna Radome is securely fitted (where applicable)	OK
Water drain plugs are fitted and removed, as appropriate	OK
Antenna sealing O-Ring is properly fitted and not damaged	OK
Antenna/Launch unit polarization is as per link requirements	OK

**SITE ACCEPTANCE CHECKLIST  
(continued)**

<b>4. OUTDOOR UNIT</b>	
Type of ODU mount:	(Direct or Remote mount)
ODU is securely mounted to the antenna or pole	OK
ODU is grounded as per installation instructions	OK
ODU's polarization is as per link requirements	OK
ODU is installed properly and has no physical damage	OK
<b><i>For Remote-Mount Only:</i></b>	
Remote mount kit is securely mounted to the pole	OK
Flexible waveguide has no physical damage and connectors are sealed	OK
All flexible waveguide bolts are secured using washers and lock-washers, as appropriate	OK
Flexible waveguide is secured to the pole	OK
<b>6. CAT5/Fiber Optic CABLE</b>	
Overall cable length:	
Cable type:	
CAT5 connectors assembled properly on the cable	OK
Cable connected securely to ODU and IDU	OK
Cable connector is covered by gland and secure by cable tie at the ODU	OK
At the ODU, cable has a service/drip loop to prevent moisture from entering the connector	OK
Cable is secured using suitable restraints to fixed points at regular intervals (0.5 m recommended)	OK
Cable has no sharp bends, kinks, or crushed areas. All bends are per manufacturer specifications	OK
Grounding is as per site specifications	OK
Cable point-of-entry to building/shelter is weather-proof	OK
Cable ends are properly labeled	OK

<b>SITE ACCEPTANCE CHECKLIST (continued)</b>	
<b>7. FLEXIBLE WAVEGUIDE</b>	
Overall flexible WG length:	
Flexible WG type:	
Flexible WG is connected securely to ODU and Antenna	OK



Flexible WG connector is weather-proofed (sealed) at the ODU	OK
At the ODU, the flexible WG has a service/drip loop to prevent moisture from entering the connector	OK
Flexible WG is secured using suitable restraints to fixed points at regular intervals (0.5 m recommended)	OK
Flexible WG has no sharp bends, kinks, or crushed areas. All bends are per manufacturer specifications	OK
Flexible WG point-of-entry to building/shelter is weather-proof	OK
Flexible WG ends are properly labeled	OK
<b>8. DC POWER SUPPLY - Two Inputs</b>	
Measured DC voltage input to the IDU:	(-40.5 to -60 VDC)
Power-Supply maximum current:	
Power-Supply is properly grounded	OK
DC power backup type:	
IDU DC connector is secure and the DC input leads are correctly terminated (no bare wires are visible)	OK
IDU DC connector (+) and (GND) leads are shorted and GND is grounded	OK
<b>9. RACK INSTALLATION</b>	
Rack is mounted to the shelter floor with four screws	OK
Rack is mounted to the shelter wall with two screws	OK

<b>SITE ACCEPTANCE CHECKLIST (continued)</b>	
<b>10. REMARKS/NOTES</b>	
<b>11. GENERAL INFORMATION</b>	
Site accepted by:	Name:
	Title:
	Company:
	Signature:
	Date:
Site approved by:	Name:
	Title:
	Company:
	Signature:
	Date:

# Site Acceptance Checklist Notes

---

The following notes provide important additional information about the Site Acceptance Checklist.

## 1. Antenna Mounting

- Mounting pole is of sufficient height to clear local obstructions, such as parapets, window cleaning gantries, and lift housings.
- Mounting Pole is of sufficient height, and is safely positioned, so as not to cause a safety hazard. No person should be able to walk in front of, or look directly into the path of the microwave radio beam. Where possible, the pole should be away from the edge of the building.
- Mounting pole is secure and perpendicular. A pole that is not perpendicular may cause problems during antenna alignment.
- Mounting pole is grounded as per site specifications. All operators and site owners have specific requirements regarding the grounding of installations. As a minimum, typical requirements are such that any metal structure must be connected to the existing lightning protection ground of the building. Where it extends beyond the 45 degree cone of protection of existing lightning conductors, additional lightning protectors should be installed.
- All steelwork is Galvanized or Stainless Steel, as appropriate to prevent corrosion.

## 2. Antenna

- Antenna is grounded as per site specifications. See the third point in the Antenna Mounting section above.
- Antenna sway braces are fitted and installed correctly, where applicable. Typically, for an antenna of 1.2 m or larger, an extra sway brace is fitted to the mounting frame of the antenna. This sway brace should not be mounted to the same pole as the antenna, but should be installed directly back to the tower or an alternative point.
- Antenna Water Drain Plugs are fitted and removed, where appropriate. Some antennas have moisture drain plugs installed at various points around the antenna. The purpose of these plugs is to allow any moisture that forms on the inside of the antenna or radome to drip out and prevent a pool within the antenna. Only the plugs at the bottom of the antenna, after installation, should be removed. All other plugs should be left in position.

## 3. ODU (Outdoor Unit)

- The ODU is grounded as per installation instructions. See the third point in the Antenna Mounting section above.
- The ODU polarization is as per link requirements and matches the polarization of the antenna.
- The main traffic connections are correctly terminated and crimped as per cable and connector manufacturer instructions. All fiber optic patch leads should be routed carefully and efficiently, using conduits to prevent damage to the cables.
- All other user terminations are secure and correctly terminated.
- All labeling is complete as per site requirements. Labeling is specific to each customer. At a site with only one installation, labeling may be unnecessary. However, at sites with multiple installations, correct and adequate labeling is essential for future maintenance operations.

Typical labeling requirements include:

- Antenna labels - for link identity and bearing
- ODU labels - for link identity, frequency, and polarization
- Cat5/Fiber cable labels - for link identity, close to the ODU, switch, and either end of any joint

- Switch labels - for link identity

# Radio Link Commissioning Procedure

---

## Scope

This section describes the recommended commissioning tests for PTP 820 radio link in a 1+0 configuration. The purpose of the commissioning tests is to verify correct and proper operation of the product.

## Commissioning Test

The following tests should be performed on each installed link.

### Link Verification

- Received Signal Level (RSL) is up to +/- 4 dB from the expected (calculated) level at both ends of the link.<sup>1</sup>
- Radio Bit Error Rate (BER) is  $10E^{-11}$  or lower.
- If working with ATPC, ATPC is operating as expected (RSL = reference level).

### Ethernet Line Interfaces Test

- Connect Ethernet Packet Analyzer to the GbE port. Use physical loop at remote end (or connect second analyzer). Run Packet Loss test for at least one hour (load rate as per Cambium's specifications for the chosen MRMC).
- Connect Ethernet Packet Analyzer to the FE port. Use physical loop at remote end (or connect second analyzer). Run Packet Loss test for at least one hour (load rate as per Cambium's specifications for the chosen MRMC).

### Interoperability Verification

- Connect customer end equipment to the line interfaces, and verify correct operation.
- Further interoperability tests should be performed in accordance with the specific requirements of the connected end equipment.

---

<sup>1</sup> The voltage at the BNC port is 1.XX where XX is the RSL level. For example: 1.59V means an RSL of -59 dBm. Note that the voltage measured at the BNC port is not accurate and should be used only as an aid).

## Management Verification

- Launch the HTTP management and verify that you can manage the link and that you are able to perform changes to the link configuration (frequency channel, Tx power, system name, time & date, etc.)
- Verify that correct parameters are reported when performing the above.
- Verify that there are no active alarms on the link.
- If the management station is located at a remote site (Network Operation Center), verify that the management station can manage the link and receive traps.

# PTP 820 Commissioning Log

---

The Commissioning Log is an integral part of the commissioning procedure and should be filled in for each installed link.

The Commissioning Log gathers all relevant information regarding the installed link and contains a checklist of all recommended commissioning tests.

Maintaining the Commissioning Log is important for tracking your installations, and to provide essential data for Cambium Networks.

Upon completing the Commissioning Log, send the log to Cambium Networks' support center at <https://support.cambiumnetworks.com>.

<b>PTP 820 LINK COMMISSIONING LOG</b>		
<b>1. GENERAL INFORMATION</b>		
Customer:		
Radio model:		
Configuration:		
Radio link code:		
Site 1 name & add:		
Site 2 name & add:		
<b>2. ODU/RFU</b>	<b>Site 1</b>	<b>Site 2</b>
ODU model:		
ODU p/n:		
ODU s/n:		
ODU SW:		
Tx frequency (MHz):		
Rx frequency (MHz):		
Link ID:		
Tx power (dBm):		
ATPC on/off:		
ATPC ref level:		
ODU Polarization:		
<b>3. ANTENNA AND ODU MOUNT</b>	<b>Site 1</b>	<b>Site 2</b>
Antenna vendor and model:		
Antenna size:		
Mounting type:		

Mounting losses:			
<b>4. LINK PARAMETERS</b>		<b>Site 1</b>	<b>Site 2</b>
Link distance:			
Rain zone:			
Expected RSL (dBm):			
Expected Diversity RSL (dBm):			
RSL Main (dBm):			
RSL Diversity (dBm):			
Deviation from exp?			
RSL ≤4 dB?			
<b>5. COMMISSIONING TESTS</b>		<b>Site 1</b>	<b>Site 2</b>
Line loopback:		Pass	Pass
ODU loopback:		Pass	Pass
Radio BER:		Pass	Pass
FE test:		Pass	Pass
GbE test:		Pass	Pass
<b>6. MANAGEMENT CONFIGURATION</b>		<b>Site 1</b>	<b>Site 2</b>
Eth IP Address:			
Eth IP mask:			
Default router:			
In-band VLAN			
<b>7. REMARKS/NOTES</b>			
<b>8. INSTALLATION INFORMATION</b>			
Installed by:	Name:		
	Company:		
	Date:		
	Signature:		
Commissioned by:	Name:		
	Company:		
	Date:		
	Signature:		