



INSTALLATION GUIDE

PTP 700



Accuracy

While reasonable efforts have been made to assure the accuracy of this document, Cambium Networks assumes no liability resulting from any inaccuracies or omissions in this document, or from use of the information obtained herein. Cambium Networks reserves the right to make changes to any products described herein to improve reliability, function, or design, and reserves the right to revise this document and to make changes from time to time in content hereof with no obligation to notify any person of revisions or changes. Cambium Networks does not assume any liability arising out of the application or use of any product, software, or circuit described herein; neither does it convey license under its patent rights or the rights of others. It is possible that this publication may contain references to, or information about Cambium Networks products (machines and programs), programming, or services that are not announced in your country. Such references or information must not be construed to mean that Cambium Networks intends to announce such Cambium Networks products, programming, or services in your country.

Copyrights

This document, Cambium Networks products, and 3rd Party software products described in this document may include or describe copyrighted Cambium Networks and other 3rd Party supplied computer programs stored in semiconductor memories or other media. Laws in the United States and other countries preserve for Cambium Networks, its licensors, and other 3rd Party supplied software certain exclusive rights for copyrighted material, including the exclusive right to copy, reproduce in any form, distribute and make derivative works of the copyrighted material. Accordingly, any copyrighted material of Cambium Networks, its licensors, or the 3rd Party software supplied material contained in the Cambium Networks products described in this document may not be copied, reproduced, reverse engineered, distributed, merged or modified in any manner without the express written permission of Cambium Networks. Furthermore, the purchase of Cambium Networks products shall not be deemed to grant either directly or by implication, estoppel, or otherwise, any license under the copyrights, patents or patent applications of Cambium Networks or other 3rd Party supplied software, except for the normal non-exclusive, royalty free license to use that arises by operation of law in the sale of a product.

Restrictions

Software and documentation are copyrighted materials. Making unauthorized copies is prohibited by law. No part of the software or documentation may be reproduced, transmitted, transcribed, stored in a retrieval system, or translated into any language or computer language, in any form or by any means, without prior written permission of Cambium Networks.

License Agreements

The software described in this document is the property of Cambium Networks and its licensors. It is furnished by express license agreement only and may be used only in accordance with the terms of such an agreement.

High Risk Materials

Cambium and its supplier(s) specifically disclaim any express or implied warranty of fitness for any high risk activities or uses of its products including, but not limited to, the operation of nuclear facilities, aircraft navigation or aircraft communication systems, air traffic control, life support, or weapons systems ("High Risk Use"). Any High Risk is unauthorized, is made at your own risk and you shall be responsible for any and all losses, damage or claims arising out of any High Risk Use.

About this guide

This guide is supplied with PTP 700 ODUs. It describes how to install the site equipment for PTP 700 Series links. Users of this guide must follow good practice for outdoor radio installations.

In more advanced configurations, there may be one or two additional Ethernet interfaces connected to the ODU: one to the SFP port (copper or optical) and one to the AUX port. For details of these configurations, refer to the PTP 700 Series User Guide.

Version information

Document number and version: phn-4174_002v000 (July 2015).

User documentation

For full PTP 700 installation planning instructions and a list of components, download the *PTP 700 Series User Guide* from: <http://support.cambiumnetworks.com/files/ptp700>

Waste Electrical and Electronic Equipment (WEEE)

For instructions on waste disposal of used products, refer to <http://www.cambiumnetworks.com/support/weee-compliance>

EU Declaration of Conformity

Hereby, Cambium Networks declares that the Cambium PTP 700 Series Wireless Ethernet Bridge complies with the essential requirements and other relevant provisions of Directive 1999/5/EC. The declaration of conformity may be consulted at: <http://www.cambiumnetworks.com/support/ec-doc>

Safety



Warning

To prevent loss of life or physical injury, observe the safety guidelines below. In no event shall Cambium Networks be liable for any injury or damage caused during the installation of the Cambium PTP 700. Ensure that only qualified personnel install a PTP 700 link.

Power lines

Exercise extreme care when working near power lines.

Working at heights

Exercise extreme care when working at heights.

PSU

Always use one of the Cambium PTP 650/700 Series power supply units (PSU) to power the ODU. Failure to use a Cambium supplied PSU could result in equipment damage and will invalidate the safety certification and may cause a safety hazard.

Grounding and protective earth

The Outdoor Unit (ODU) must be properly grounded to protect against lightning. It is the user's responsibility to install the equipment in accordance with national regulations. In the USA follow the requirements of the National Electrical code NFPA 70-2005 and 780-2004 *Installation of Lightning Protection Systems*. In Canada, follow Section 54 of the *Canadian Electrical Code*. These codes describe correct installation procedures for grounding the outdoor unit, mast, lead-in wire and discharge unit, size of grounding conductors and connection requirements for grounding electrodes. Other regulations may apply in different countries and therefore it is recommended that installation of the outdoor unit be contracted to a professional installer.

DC supply

To power the ODU from a DC supply, use the AC+DC enhanced power injector (PSU) (Cambium part number C000065L002). Ensure that the DC power supply meets the requirements specified in the *PTP 700 Series User Guide*.

Powering down before servicing

Before servicing PTP 700 equipment, always switch off the power supply and unplug it from the PSU.

Do not disconnect the RJ45 drop cable connectors from the ODU while the PSU is connected to the power supply. Always remove the AC or DC input power from the PSU.

Primary disconnect device

The main power supply is the primary disconnect device. The AC-DC enhanced power injector is fused on the DC input. Some installations will also require an additional circuit breaker or isolation switch to be fitted in the DC supply.

External cables

Safety may be compromised if outdoor rated cables are not used for connections that will be exposed to the outdoor environment. For outdoor copper Cat5e Ethernet interfaces, always use Cat5e cable that is gel-filled and shielded with copper-plated steel. Alternative types of drop cable are not supported by Cambium Networks for use with PTP 700.

Drop cable tester

A drop cable tester must NEVER be used at the ODU end connected to the power supply from the PSU. It must only be used at the bottom of the mast with a multimeter. This is because the PSU voltage exceeds the limit allowed in some countries for safe handling in wet conditions and therefore may create a safety hazard.

RF exposure near the antenna

Strong radio frequency (RF) fields will be present close to the antenna when the transmitter is on. Always turn off the power to the ODU before undertaking maintenance activities in front of the antenna.

Minimum separation distances

Ensure that personnel are not exposed to unsafe levels of RF energy. The units start to radiate RF energy as soon as they are powered up. Never work in front of the antenna when the ODU is powered. Install the ODUs so as to provide and maintain the minimum separation distances from all persons. For minimum separation distances, see the *PTP 700 Series User Guide*.

Grounding and lightning protection requirements

Ensure that the installation meets the requirements defined in the *PTP 700 Series User Guide*.

Grounding cable installation methods

To provide effective protection against lightning induced surges, observe these requirements:

- 1 Grounding conductor runs must be as short, straight and smooth as possible, with bends and curves kept to a minimum.
- 2 Grounding cables must not be installed with drip loops.
- 3 All bends must have a minimum radius of 203 mm (8 in) and a minimum angle of 90°. A diagonal run is preferable to a bend, even though it does not follow the contour or run parallel to the supporting structure.
- 4 All bends, curves and connections must be routed towards the grounding electrode system, ground rod, or ground bar.
- 5 Grounding conductors must be securely fastened.
- 6 Braided grounding conductors must not be used.
- 7 Approved bonding techniques must be used for the connection of dissimilar metals.

Siting ODUs and antennas

ODUs and external antennas are not designed to survive direct lightning strike. For this reason they must be installed in Zone B as defined in *PTP 700 Series User Guide*. Mounting in Zone A may put equipment, structures and life at risk.

Typical deployment

A PTP 700 site typically consists of a high supporting structure such as a mast, tower or building for the outdoor equipment (ODU and optional external antenna); and an equipment building or moisture-proof enclosure for the indoor equipment (PSU), as shown here in a typical mast or tower installation:

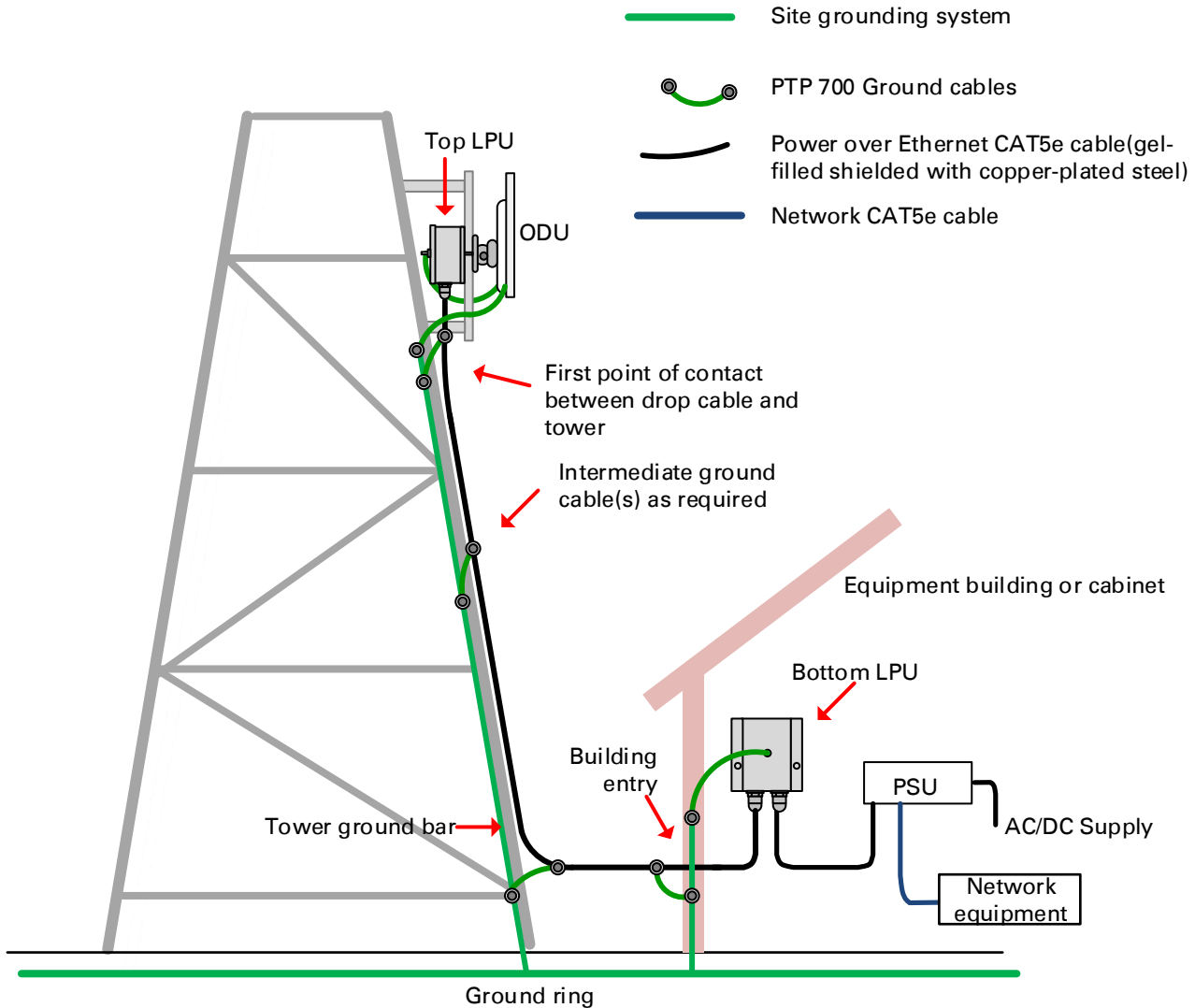

Note

These instructions assume that LPUs are being installed from the PTP 650/700 LPU and grounding kit (Cambium part number C000065L007). If the installation does not require LPUs, adapt these instructions as appropriate.

If LPUs are being installed, only use the five black-capped EMC cable glands supplied in the LPU and grounding kit. The silver-capped cable glands supplied in the ODU kits must only be used in PTP 700 installations which do not require LPUs.

ODU variants and mounting bracket options

ODU variants

The PTP 700 ODU is supplied in two configurations.

The PTP 700 Connectorized+Integrated ODU provides a choice between using external antennas, similar to the Connectorized ODU, or a 21 dBi integrated antenna. The integrated antenna offers a convenient and easily-deployed solution where the additional gain of external antennas is not needed.



The PTP 700 Connectorized ODU is intended to work with separately mounted external antennas. External antennas generally have higher gains than the integrated antennas, allowing the PTP 700 to cope with more difficult radio conditions.



Mounting bracket options

The PTP 700 series supports four mounting bracket options. Select the optimum mounting bracket arrangement based on the pole diameter and the ODU variant:

Bracket	Pole diameter	ODU variants	Bracket part number
Mounting bracket (integrated)	40 mm to 82 mm (1.6 inches to 3.2 inches)	PTP 700 Connectorized+Integrated	N000065L031
Mounting bracket (connectorized)	40 mm to 82 mm (1.6 inches to 3.2 inches)	PTP 700 Connectorized PTP 700 Connectorized+Integrated	N000065L032
Extended integrated mounting bracket	89 mm <i>OR</i> 114 mm (3.5 inches <i>OR</i> 4.5 inches)	PTP 700 Connectorized PTP 700 Connectorized+Integrated	N000065L030
Mounting bracket (integrated) with large diameter extension kit	89 mm to 229 mm (3.5 inches to 9.0 inches)	PTP 700 Connectorized PTP 700 Connectorized+Integrated	N000065L031 with N000065L042



Note

The connectorized mounting bracket is included with the PTP 700 Connectorized ODU. Order a bracket separately for PTP 700 Connectorized+Integrated ODUs.

Installing the ODU and top LPU

Attach ground cables to the ODU

- 1 Fasten one ground cable to each ODU grounding point using the M6 (small) lugs: one is for the top LPU (M6 lug at other end) and the other is for the tower or building (M10 lug at other end). It does not matter which cable goes on which ODU grounding point.
- 2 Tighten both ODU grounding bolts to a torque of 5.0 Nm (3.7 lb ft).

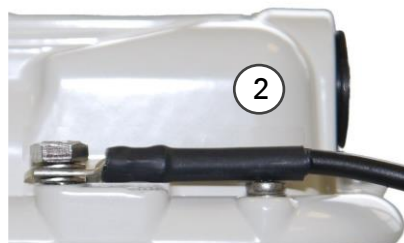

Mount the ODU on the mast

Select the most appropriate bracket mounting arrangement from the options listed in [Mounting bracket options](#) on page 8.

Refer to individual procedures below for each of the options:

- 1 [Mounting bracket \(integrated\)](#) on page 10
- 2 [Mounting bracket \(connectorized\)](#) on page 10
- 3 [Extended integrated mounting bracket](#) on page 12
- 4 [Mounting bracket \(integrated\) with large diameter extension kit](#) on page 13

The procedure for the Mounting bracket (connectorized) can be readily adapted to attach the ODU to a horizontal pole of similar size.

The procedure for the Mounting bracket (integrated) and the Extended integrated mounting bracket can be adapted to attach the ODU to a suitable horizontal pole, but the adjustment of azimuth angle is necessarily limited compared with an installation on a vertical pole.

Mounting bracket (integrated)



Caution

Do not reverse the bracket clamp, as this arrangement may lead to failure of the assembly. Do not over-tighten the bolts as this may lead to failure of the assembly.

- 1 Fix the mounting plate to the back of the ODU using the four bolts, and spring and plain washers provided. Tighten the bolts to a torque setting of 5.0 Nm (3.7 lb ft).
- 2 Attach the bracket body to the mounting plate using the M8 bolt, and spring and plain washers.
- 3 Hoist the ODU to the mounting position.
- 4 Attach the bracket body to the pole using the bracket clamp, M8 bolts, and spring and plain washers. For back-to-back mounting, use the LPU in place of the clamp.
- 5 Adjust the elevation and azimuth to achieve visual alignment. Tighten all three bracket bolts to a torque of 8.0 Nm (5.9 lb ft).

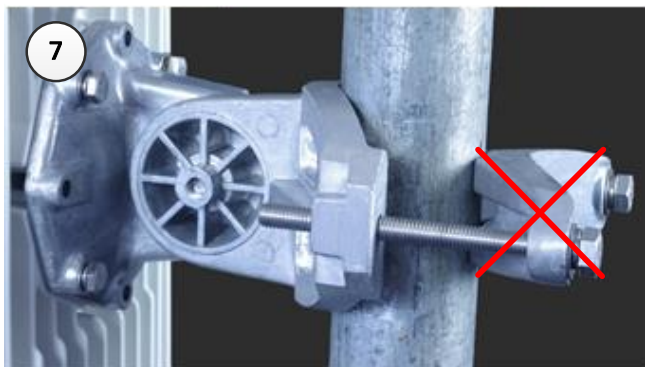
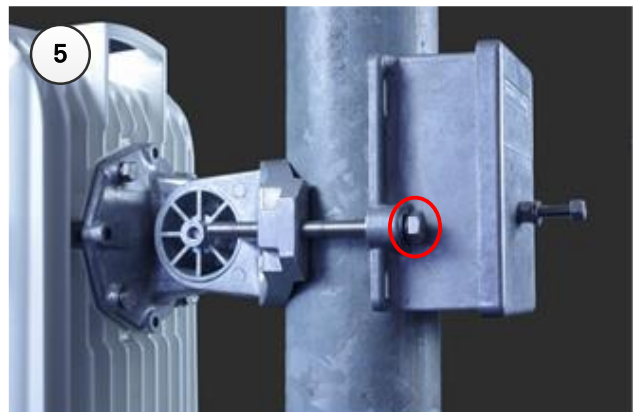
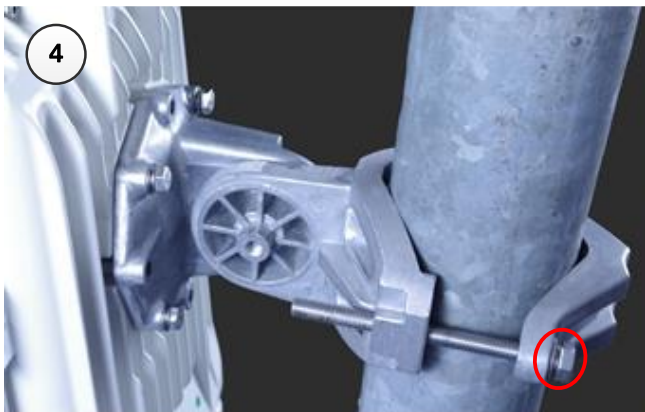
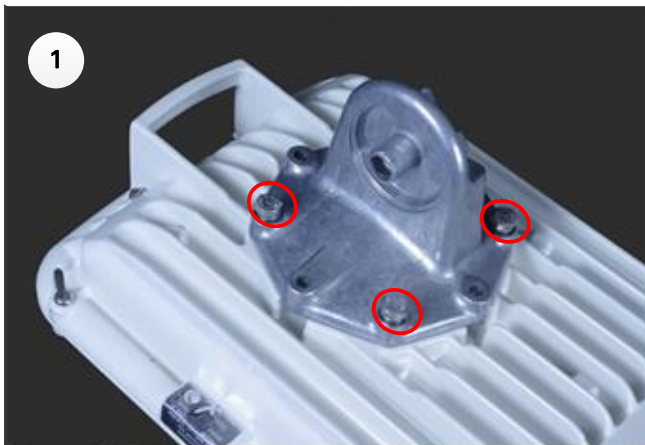

Mounting bracket (connectorized)

- 1 Identify the square cavities in the casting on the back of the ODU. These cavities will be used to accommodate the heads of two M8 bracket bolts.
- 2 Fix the mounting plate to the ODU using the four M6 bolts, and spring and plain washers provided.
- 3 Hoist the ODU to the mounting position.
- 4 Attach the bracket body to the pole using the bracket clamp, spring and plain washers, and M8 nuts.
- 5 Alternatively, use the LPU in place of the clamp to provide a back-to-back arrangement.
- 6 Tighten the two M8 bracket bolts to a torque setting of 8.0 Nm (5.9 lb ft). Do not over-tighten the bolts as this may lead to failure of the assembly.

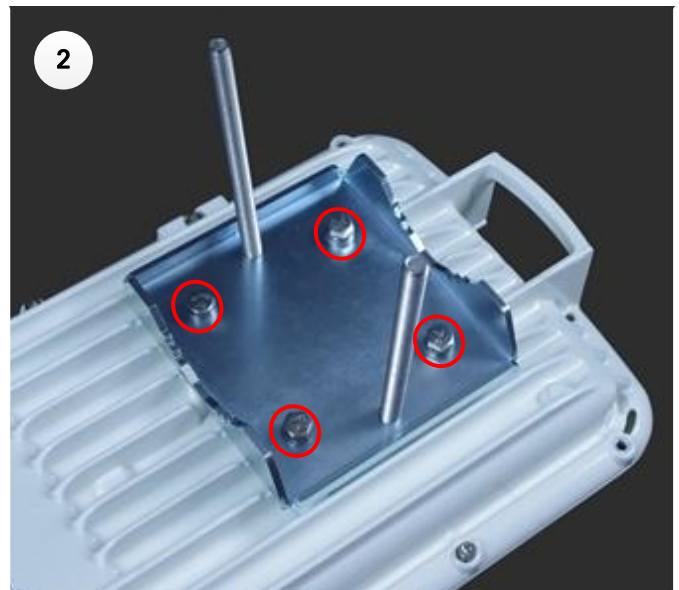
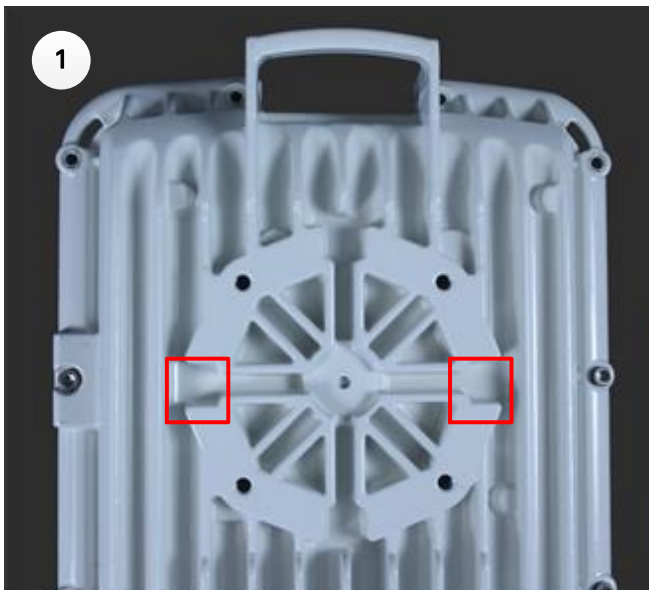

Extended integrated mounting bracket

- 1 Fix the mounting plate to the back of the ODU using the four M6 bolts, and spring and plain washers provided. Tighten the bolts to a torque setting of 5.0 Nm (3.7 lb ft). The step is common with the standard integrated bracket.
- 2 Attach the bracket body of the extended bracket on the mounting plate on the ODU to using the M8 bolt and spring and plain washer.
- 3 Hoist the ODU to the mounting position.
- 4 Select the correct clamp. The larger clamp is intended for poles of diameter 114 mm (4.5 inches). The smaller clamp is intended for poles of diameter 89 mm (3.5 inches).
- 5 Attach the bracket body to the pole using the selected bracket clamp, washers and M8 bolts.
- 6 Adjust the elevation and azimuth to achieve visual alignment. Tighten all three M8 bracket bolts to a torque setting of 8.0 Nm (5.9 lb ft). Do not over-tighten the bolts as this may lead to failure of the assembly.

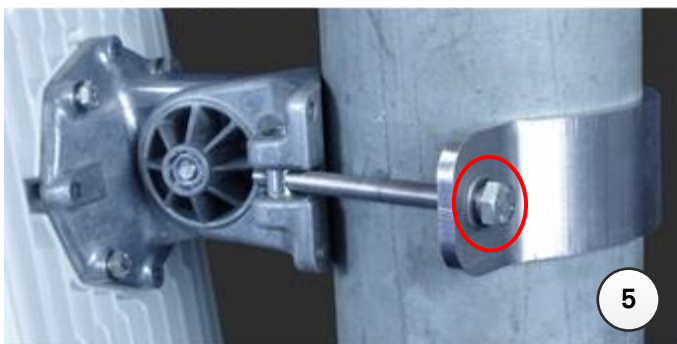
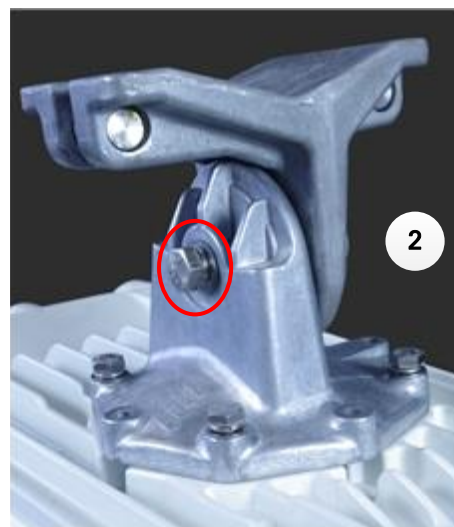

Mounting bracket (integrated) with large diameter extension kit

- 1 Fix the mounting plate to the back of the ODU using the bolts and washers provided. Tighten the four bolts to a torque setting of 5.0 Nm (3.7 lb ft). Attach the bracket body to the mounting plate using the M8 bolt and spring and plain washer. This is equivalent to the first two steps for the standard integrated bracket.
- 2 Attach the adaptor plate of the large diameter extension kit to the bracket body using the bolts and washers provided. Tighten the two bolts to a torque setting of 5.0 Nm (3.7 lb ft).
- 3 Feed the Jubilee straps through the slots in the adaptor plate.
- 4 Hoist the ODU to the mounting position.
- 5 Attach the adaptor plate to the pole using the Jubilee straps.
- 6 Adjust the azimuth to achieve visual alignment. Tighten the Jubilee straps to a torque setting of 6.0 Nm (4.4 lb ft).
- 7 Adjust the elevation to achieve visual alignment. Tighten M8 bracket bolt to a torque setting of 8.0 Nm (5.9 lb ft). Do not over-tighten this bolt as this may lead to failure of the assembly.

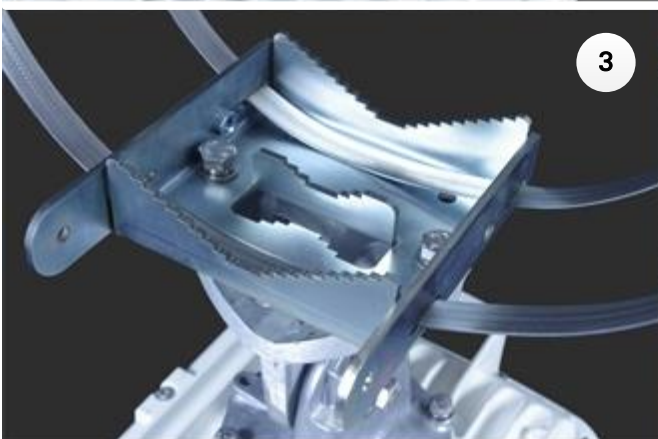
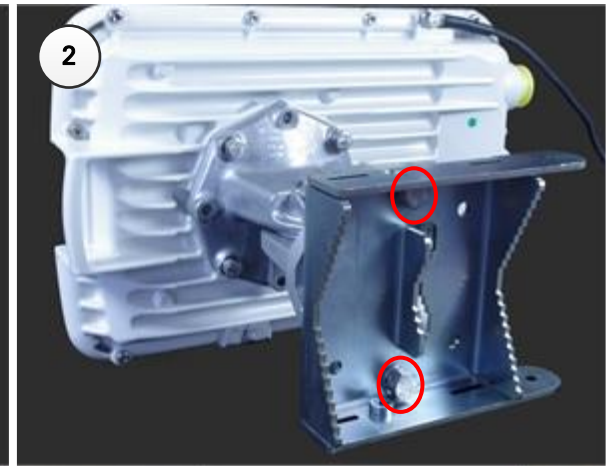
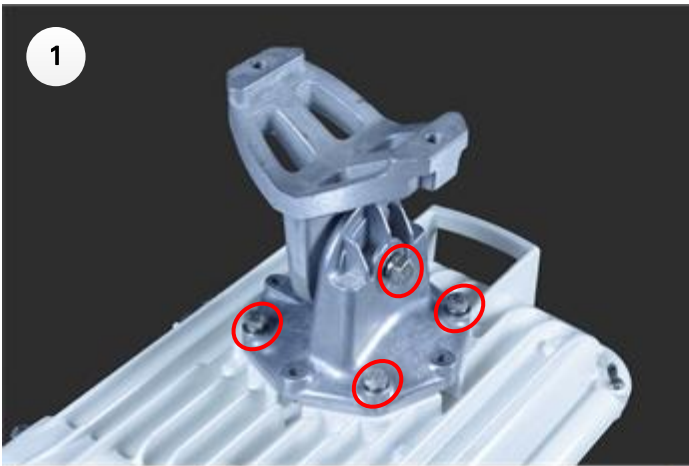

Mount the top LPU

- 1 For separate LPU mounting, use the U-bolt bracket from the LPU kit to mount the top LPU on the pole below the ODU. Tighten to a torque setting of 7.0 Nm (5.2 lb ft):

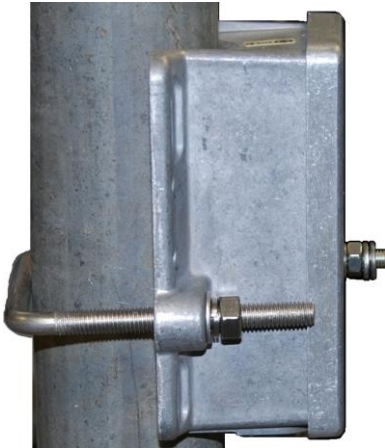

Interconnect and ground the ODU and top LPU

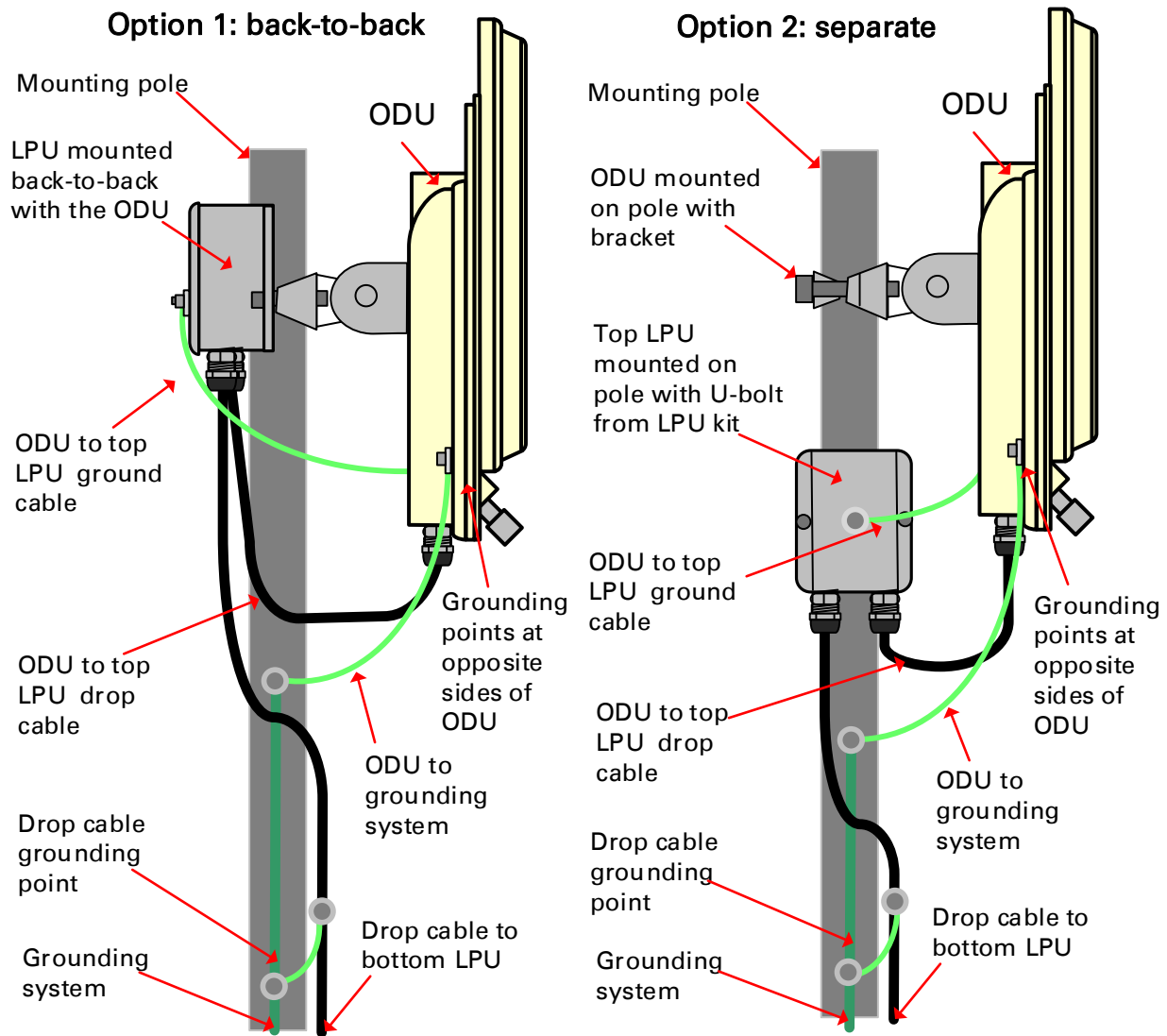



Caution

Do not attach grounding cables to the ODU mounting bracket bolts, as this arrangement will not provide full protection.

- 1 Fasten the ODU grounding cable to the top LPU using the M6 (small) lug. Tighten both nuts to a torque of 5 Nm (3.7 lb ft):

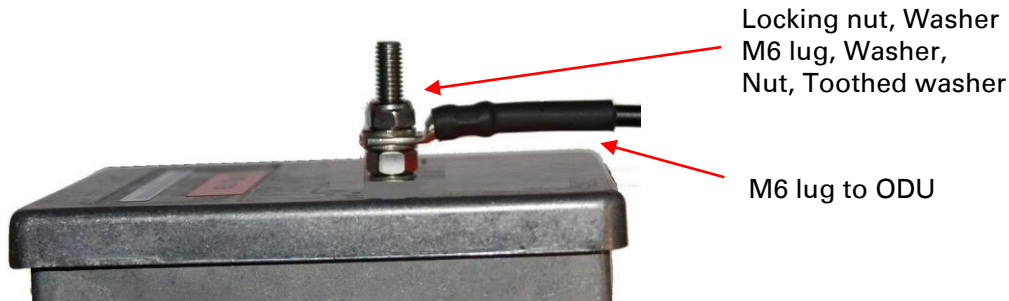

- 2 Select a tower or building grounding point within 0.3 meters (1 ft) of the ODU bracket. Remove paint from the surface and apply anti-oxidant compound. Fasten the ODU grounding cable to this point using the M10 (large) lug.
- 3 If local regulations mandate the independent grounding of all devices, add a third ground cable to connect the top LPU directly to the grounding system.

Install external antennas for a connectorized or Connectorized+Integrated ODU

- 1 Mount the antenna(s) according to manufacturer's instructions. When using separate antennas to achieve spatial diversity, mount one with Horizontal polarization and the other with Vertical polarization.
- 2 Connect the ODU V and H interfaces to the antenna(s) with RF cable of type CNT-400 (Cambium part numbers 30010194001 and 30010195001) and N type connectors (Cambium part number 09010091001). Tighten the N type connectors to a torque setting of 1.7 Nm (1.3 lb ft) using 24 mm (0.9 in) wrench/spanner.
- 3 If the ODU is mounted indoors, install lightning arrestors at the building entry point:
- 4 Form drip loops near the lower ends of the antenna cables. These ensure that water is not channeled towards the connectors.
- 5 If the ODU is mounted outdoors, weatherproof the N type connectors (when antenna alignment is complete) using PVC tape and self-amalgamating rubber tape.
- 6 Weatherproof the antenna connectors in the same way (unless the antenna manufacturer specifies a different method).

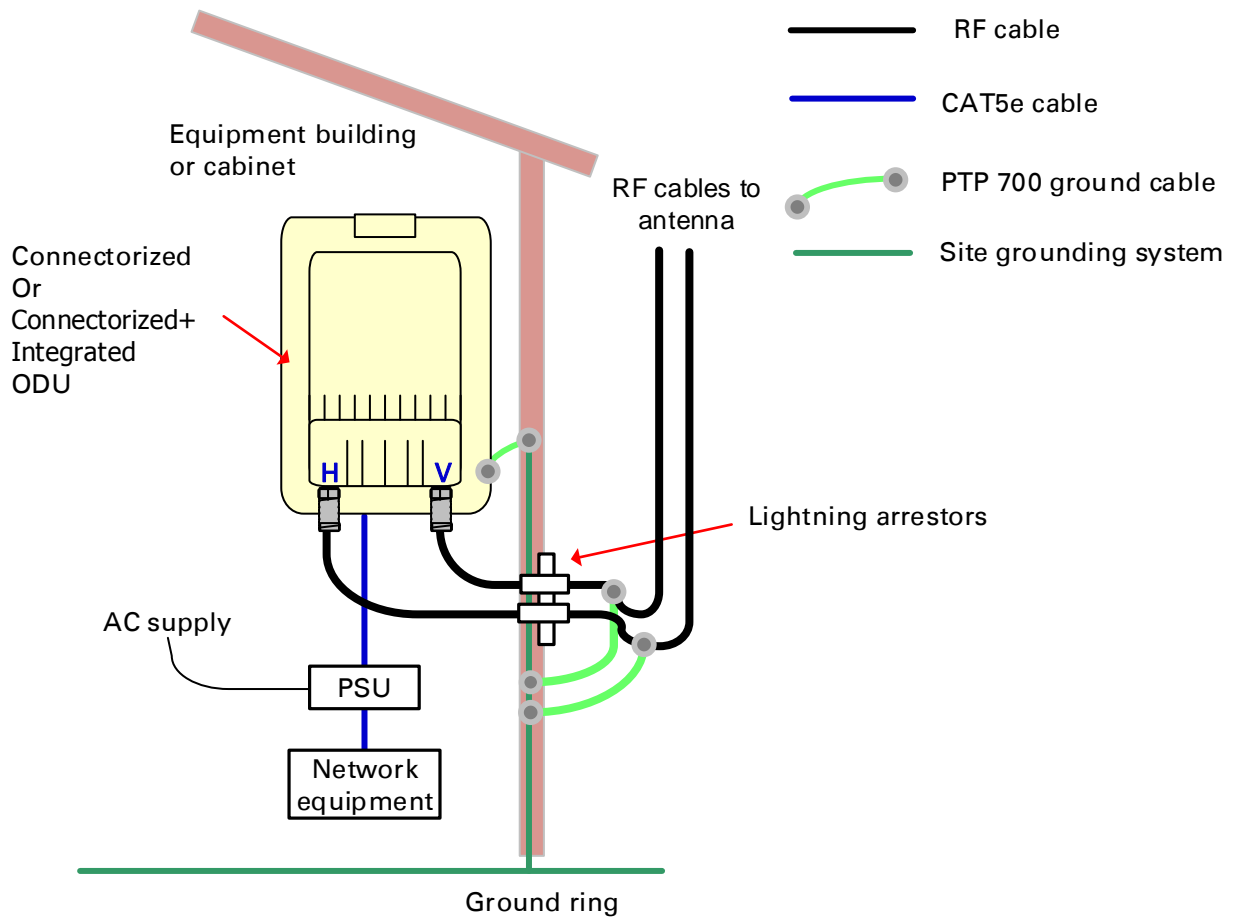

7 Ground the antenna cables to the supporting structure within 0.3 meters (1 foot) of the ODU and antennas using the Cambium grounding kit (part number 01010419001):

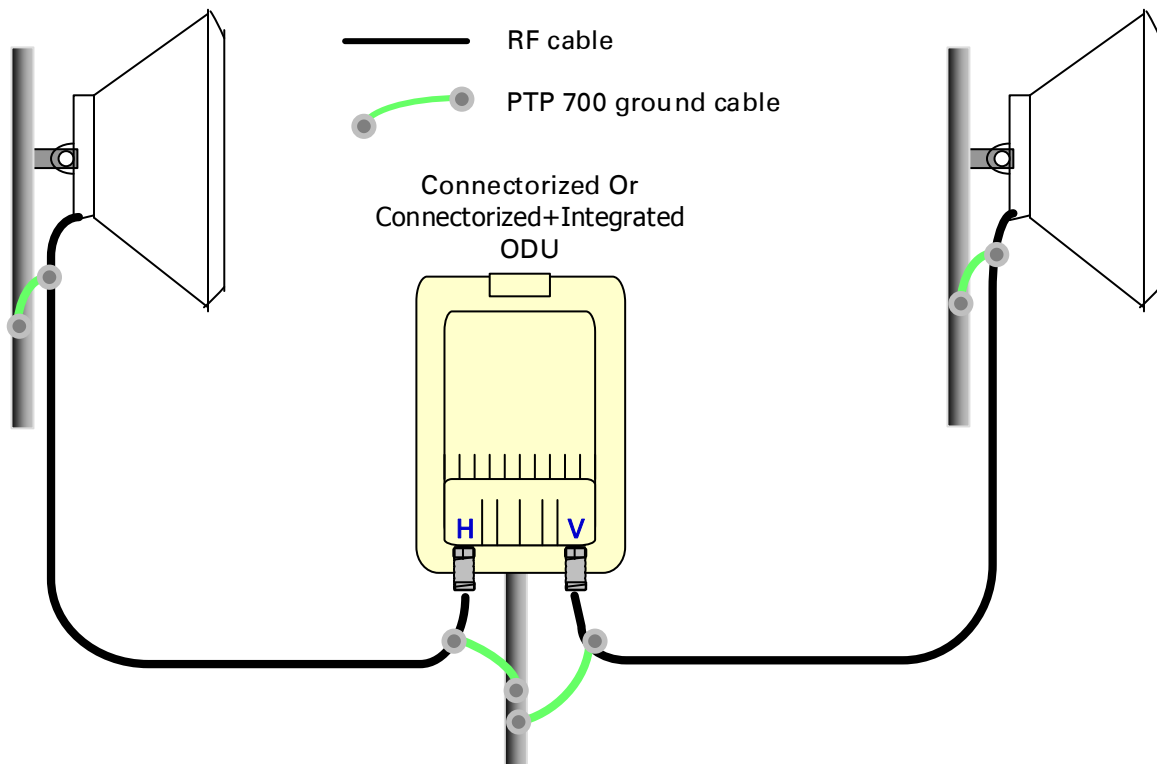

8 Fix the antenna cables to the supporting structure using site approved methods. Ensure that no undue strain is placed on the ODU or antenna connectors. Ensure that the cables do not flap in the wind, as flapping cables are prone to damage and induce unwanted vibrations in the supporting structure.

Installing the copper Cat5e Ethernet interface

To install the copper Cat5e Ethernet interface, use the following procedures:

- 1 [Install the ODU to top LPU drop cable](#) on page 17
- 2 [Install the main drop cable](#) on page 19
- 3 [Install the bottom LPU to PSU drop cable](#) on page 22
- 4 [Test resistance in the drop cable](#) on page 24



Caution

To avoid damage to the installation, do not connect or disconnect the drop cable when power is applied to the PSU or network terminating equipment.



Caution

Do not connect the SFP or Aux drop cables to the PSU, as this may damage equipment.



Caution

Always use Cat5e cable that is gel-filled and shielded with copper-plated steel. Alternative types of Cat5e cable are not supported by Cambium Networks. Cambium Networks supply this cable (Cambium part numbers WB3175 and WB3176), RJ45 connectors (Cambium part number WB3177) and a crimp tool (Cambium part number WB3211). The LPU and grounding kit contains a 0.6 meters (2 foot) length of this cable.

Install the ODU to top LPU drop cable

Fit glands to the ODU to top LPU drop cable

Fit EMC strain relief cable glands (with black caps) to both ends of the 0.6 meters (2 foot) length of pre-terminated cable. These parts are supplied in the LPU and grounding kit.

- 1 Disassemble the gland and thread each part onto the cable (the rubber bung is split). Assemble the spring clip and the rubber bung:

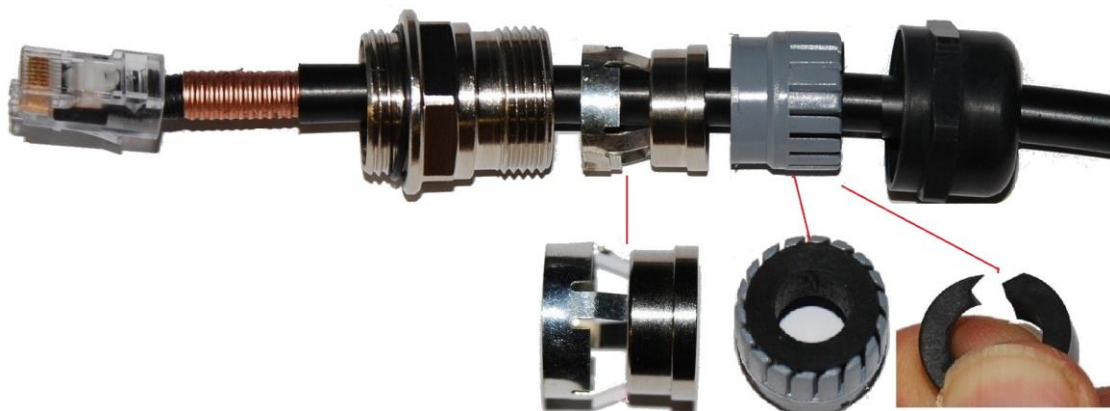

- 2 Fit the parts into the body and lightly screw on the gland nut using 24 mm (0.9 in) wrench/spanner (do not tighten it):

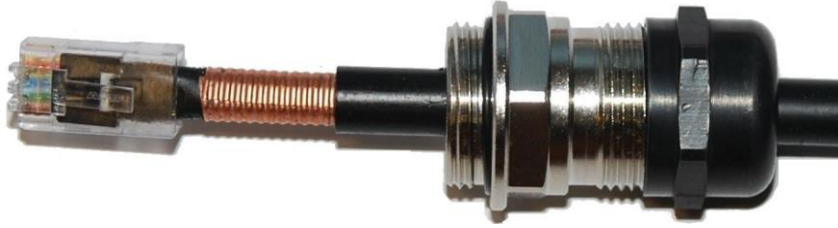

Connect the drop cable to the ODU (PSU port) and LPU

- 1 (a) Plug the RJ45 connector into the socket in the unit, ensuring that it snaps home.
(b) Fit the gland body to the RJ45 port and tighten it to a torque of 5.5 Nm (4.1 lb ft):

(a)



(b)



- 2 (a) Fit the gland nut and tighten until the rubber seal closes on the cable. (b) Do not over-tighten the gland nut, as there is a risk of damage to its internal components:

(a)



(b)

Correct



Incorrect



Disconnect the drop cable from the LPU or ODU

Use this procedure if it is necessary to remove an EMC strain relief cable gland and RJ45 connector from the ODU (as illustrated) or LPU.

- 1 (a) Remove the gland nut. Wiggle the drop cable to release the tension of the gland body. When the tension in the gland body is released, a gap opens at the point show. Unscrew the gland body.
(b) Use a small screwdriver to press the RJ45 locking tab, then remove the RJ45 connector.

(a)



(b)



Install the main drop cable



Warning

The metal screen of the drop cable is very sharp and may cause personal injury.

- ALWAYS wear cut-resistant gloves (check the label to ensure they are cut resistant).
- ALWAYS wear protective eyewear.
- ALWAYS use a rotary blade tool to strip the cable (DO NOT use a bladed knife).



Warning

Failure to obey the following precautions may result in injury or death:

- Use the proper hoisting grip for the cable being installed. If the wrong hoisting grip is used, slippage or insufficient gripping strength will result.
- Do not reuse hoisting grips. Used grips may have lost elasticity, stretched, or become weakened. Reusing a grip can cause the cable to slip, break, or fall.
- The minimum requirement is one hoisting grip for each 60 m (197 ft) of cable.

Cut to length and fit hoisting grips

- 1 Cut the main drop cable to length from the top LPU to the bottom LPU.
- 2 Slide one or more hoisting grips onto the top end of the drop cable.
- 3 Secure the hoisting grip to the cable using a special tool, as recommended by the manufacturer.

Terminate with RJ45 connectors and glands



Caution

Check that the crimp tool matches the RJ45 connector, otherwise the cable or connector may be damaged.

- 1 Thread the cable gland (with black cap) onto the main drop cable.
- 2 Strip the cable outer sheath and fit the RJ45 connector load bar.
- 3 Fit the RJ45 connector housing as shown. To ensure there is effective strain relief, locate the cable inner sheath under the connector housing tang. Do not tighten the gland nut:

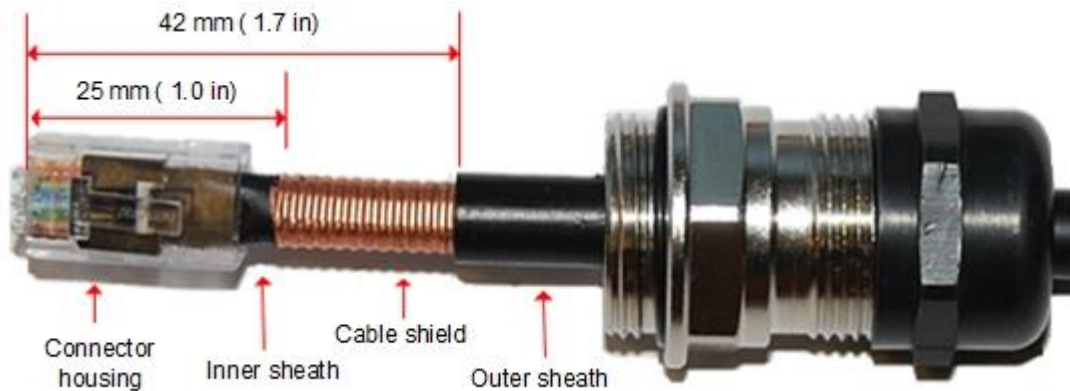

Pin	Color (Supplied cable)	Color (Conventional)	Pins on plug face
1	Light Orange	White/Orange	
2	Orange	Orange	
3	Light Green	White/Green	
4	Blue	Blue	
5	Light Blue	White/Blue	
6	Green	Green	
7	Light Brown	White/Brown	
8	Brown	Brown	

Hoist and fix the main drop cable



Warning

Failure to obey the following precautions may result in injury or death:

- Use the hoisting grip to hoist one cable only. Attempting to hoist more than one cable may cause the hoisting grip to break or the cables to fall.
 - Do not use the hoisting grip for lowering cable unless the clamp is securely in place.
 - Maintain tension on the hoisting grip during hoisting. Loss of tension can cause dangerous movement of the cable and result in injury or death to personnel.
 - Do not release tension on the grip until after the grip handle has been fastened to the supporting structure.
 - Do not apply any strain to the RJ45 connectors.
-



Caution

Do not lay the drop cable alongside a lightning air terminal.

- 1 Hoist the top end of the main drop cable up to the top LPU, following the hoist manufacturer's instructions. When the cable is in position, fasten the grip handle to the supporting structure and remove the hoist line.
- 2 Connect the main drop cable to the top LPU by following the procedure [Connect the drop cable to the ODU \(PSU port\) and LPU](#) on page 18.
- 3 Run the main drop cable to the site of the bottom LPU.
- 4 Attach the main drop cable to the supporting structure using site approved methods.

Ground the main drop cable

At all required grounding points, connect the screen of the main drop cable to the metal of the supporting structure using the cable grounding kit (Cambium part number 01010419001).

Install the bottom LPU to PSU drop cable

Install the bottom LPU

Install the bottom LPU, ground it, and connect it to the main drop cable.

- 1 Select a mounting point for the bottom LPU within 0.6 meters (2 foot) of the building entry point. Mount the LPU vertically with cable glands facing downwards.

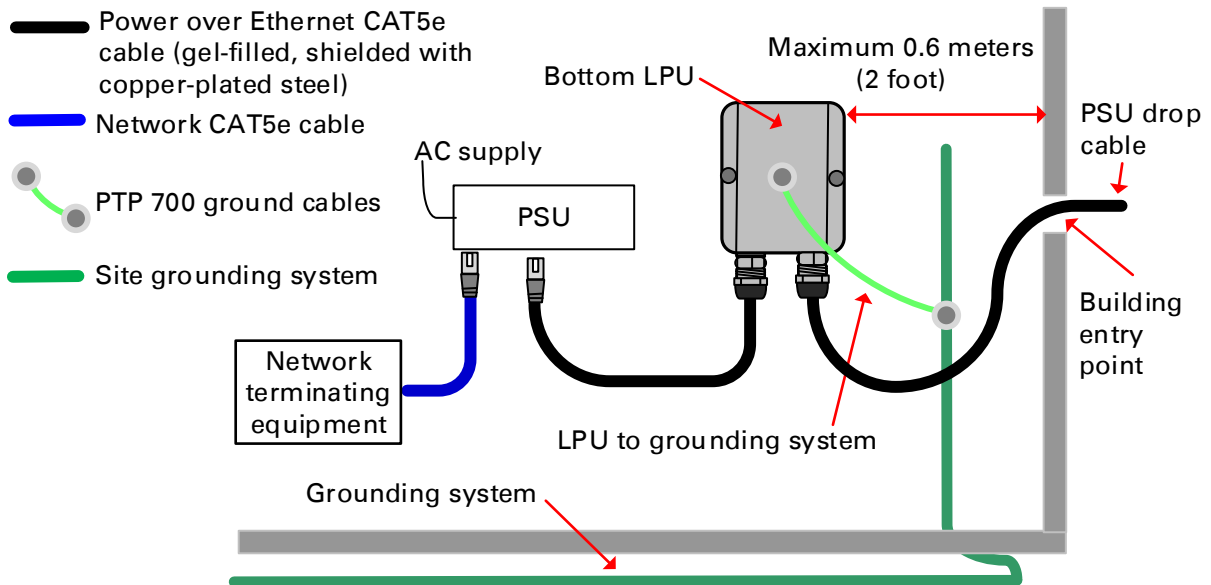

- 2 Connect the main drop cable to the bottom LPU by following the procedure [Connect the drop cable to the ODU \(PSU port\) and LPU](#) on page 18.
- 3 Fasten one ground cable to the bottom LPU using the M6 (small) lug. Tighten both nuts to a torque of 5 Nm (3.7 lb ft):

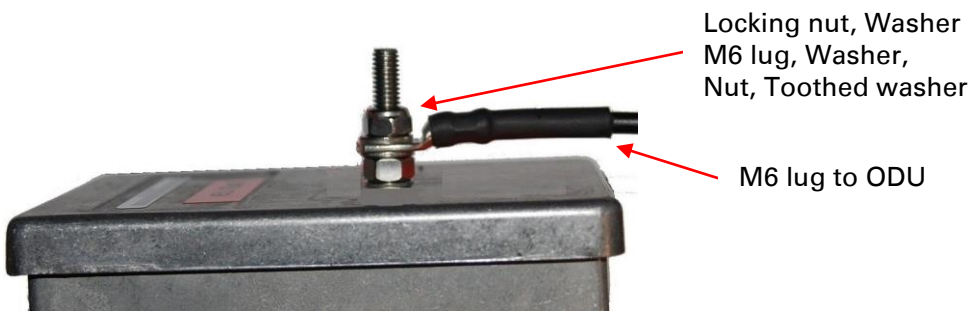

- 4 Select a building grounding point near the LPU bracket. Remove paint from the surface and apply anti-oxidant compound. Fasten the LPU ground cable using the M10 (large) lug.

Install the LPU to PSU drop cable

Use this procedure to terminate the bottom LPU to PSU drop cable with RJ45 connectors at both ends, and with a cable gland at the LPU end.



Warning

The metal screen of the drop cable is very sharp and may cause personal injury. ALWAYS wear cut-resistant gloves (check the label to ensure they are cut resistant). ALWAYS wear protective eyewear. ALWAYS use a rotary blade tool to strip the cable, not a bladed knife.



Caution

Check that the crimp tool matches the RJ45 connector, otherwise the cable or connector may be damaged.

- 1 Cut the drop cable to the length required from bottom LPU to PSU.
- 2 At the LPU end only:
 - Fit one cable gland and one RJ45 connector by following the procedure [Terminate with RJ45 connectors and glands](#) on page 20.
 - Connect this cable and gland to the bottom LPU by following the procedure [Connect the drop cable to the ODU \(PSU port\) and LPU](#) on page 18.
- 4 **At the PSU end only:** Do not fit a cable gland. Strip the cable outer sheath and fit the RJ45 connector load bar. Fit the RJ45 connector housing. To ensure there is effective strain relief, locate the cable inner sheath under the connector housing tang:



Test resistance in the drop cable

Test that the resistances between pins are within the correct limits, as specified in the table below. If any of the tests fail, examine the drop cable for wiring faults.

Connection to a terminated cable can be achieved reliably by use of a suitable cable adaptor. One example is the Modapt adaptor manufactured by The Siemon Company.

Cable length		Maximum Resistance (Ohm) between RJ45 pins		
Ft	m	1 & 2, 3 & 6, 4 & 5, 7 & 8	1 & 3	4 & 7
0	0	0.8	1	1.6
33	10	2.5	2.7	3.3
66	20	4.2	4.4	5
88	30	5.9	6.1	6.7
131	40	7.6	7.8	8.4
164	50	9.3	9.5	10.1
197	60	11	11.2	11.8
230	70	12.7	12.9	13.5
262	80	14.4	14.6	15.2
295	90	16.1	16.3	16.9
328	100	17.8	18	18.6
656	200	34.8	35	35.6
984	300	51.8	52	52.6

Ensure that the following values are within specified range in Adaptor before proceeding with the test:

Minimum Resistance (Ohm) between Adaptor pins		
1 & Screen	8 & Screen	1 & 7
> 100 K	> 100 K	> 2 K

Installing the PSU

Install the PTP 650/700 AC+DC Enhanced Power Injector (Cambium part number C000065L002). Refer to [Installing the AC+DC enhanced power injector](#) on page 25.



Caution

As the PSU is not waterproof, locate it away from sources of moisture, either in the equipment building or in a ventilated moisture-proof enclosure. Do not locate the PSU in a position where it may exceed its temperature rating.



Caution

Do not plug any device other than a PTP 650 or PTP 700 ODU into the ODU port of the PSU. Other devices may be damaged due to the non-standard techniques employed to inject DC power into the Ethernet connection between the PSU and the ODU.

Do not plug any device other than a Cambium PTP 650/700 PSU into the PSU port of the ODU. Plugging any other device into the PSU port of the ODU may damage the ODU and device.

Installing the AC+DC enhanced power injector

Follow this procedure to install the AC+DC enhanced power injector (Cambium part number C000065L002):

- 1 Mount the AC+DC power injector by screwing it to a vertical or horizontal surface using the four screw holes (circled):

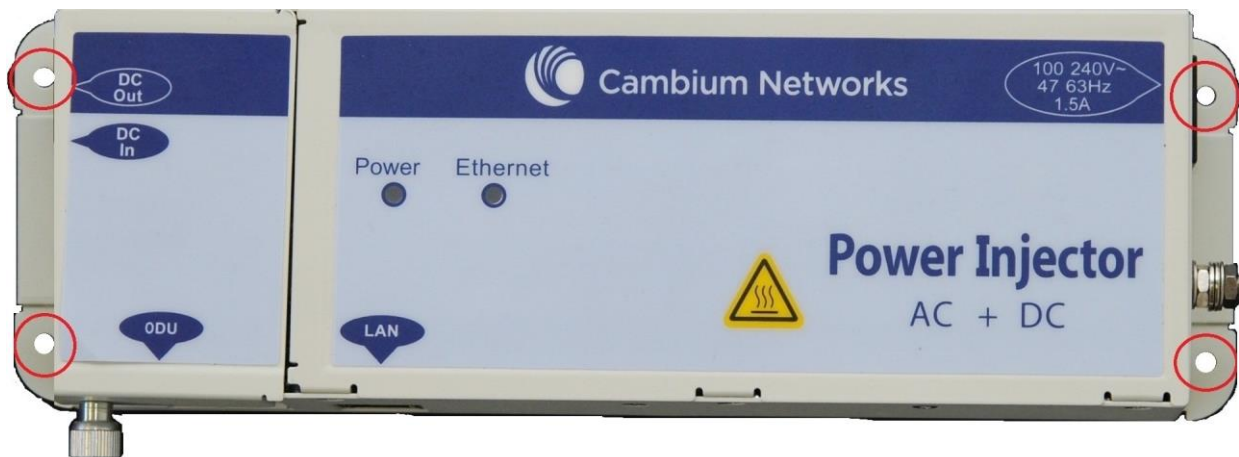

- 2 Form a drip loop on the PSU end of the LPU to PSU drop cable. The drip loop ensures that any moisture that runs down the cable into the cabinet or enclosure cannot enter the PSU.
- 3 (a) Undo the retaining screw, hinge back the cover and plug the drop cable into the port. (b) Close the cover and secure with the screw. (c) When the system is ready for network connection, connect the network Cat5e cable to the LAN port of the PSU:

(a)



(b) and (c)



Cambium Networks

Cambium Networks provides professional grade fixed wireless broadband and microwave solutions for customers around the world. Our solutions are deployed in thousands of networks in over 153 countries, with our innovative technologies providing reliable, secure, cost-effective connectivity that's easy to deploy and proven to deliver outstanding performance.

Our award-winning Point to Point (PTP) radio solutions operate in licensed, unlicensed and defined use frequency bands including specific FIPS 140-2 solutions for the U.S. Federal market. Ruggedized for 99.999% availability, our PTP solutions have an impeccable track record for delivering reliable high-speed backhaul connectivity even in the most challenging non-line-of-sight RF environments.

Our flexible Point-to-Multipoint (PMP) solutions operate in the licensed, unlicensed and federal frequency bands, providing reliable, secure, cost effective access networks. With more than three million modules deployed in networks around the world, our PMP access network solutions prove themselves day-in and day-out in residential access, leased line replacement, video surveillance and smart grid infrastructure applications.

Cambium Networks solutions are proven, respected leaders in the wireless broadband industry. We design, deploy and deliver innovative data, voice and video connectivity solutions that enable and ensure the communications of life, empowering personal, commercial and community growth virtually everywhere in the world.

Support website:	http://www.cambiumnetworks.com/support
Main website:	http://www.cambiumnetworks.com
Sales enquiries:	solutions@cambiumnetworks.com
Support enquiries:	support@cambiumnetworks.com
Telephone number list:	http://www.cambiumnetworks.com/support/contact-support
Address:	Cambium Networks Limited, Linhay Business Park, Eastern Road, Ashburton, Devon, UK, TQ13 7UP



www.cambiumnetworks.com

Cambium Networks and the stylized circular logo are trademarks of Cambium Networks, Ltd. All other trademarks are the property of their respective owners.

© Copyright 2015 Cambium Networks, Ltd. All rights reserved.